

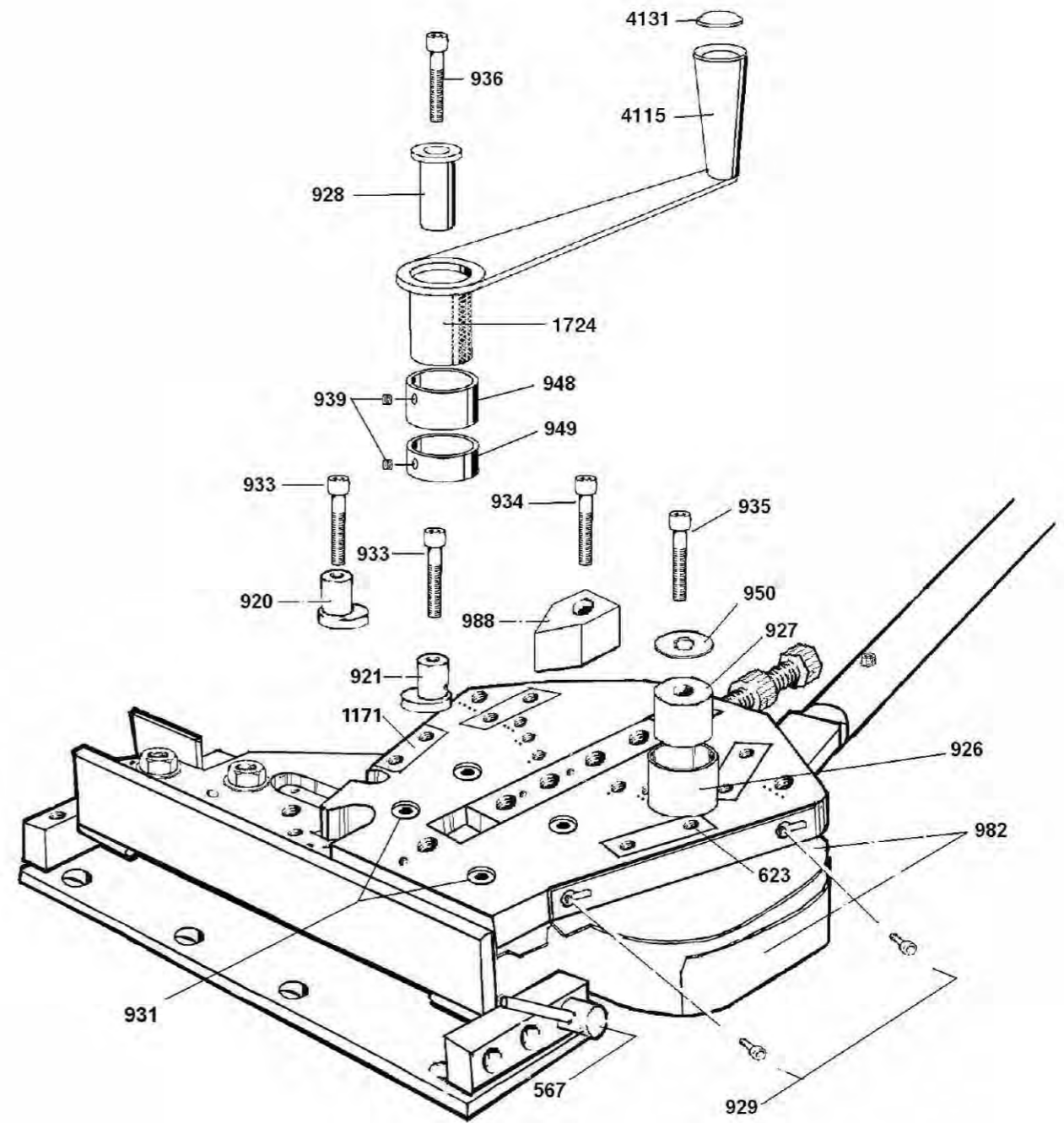

**J&C R WOOD**  
66 CLOUGH ROAD, HULL HU5 1SR • TEL: 01482 345067 • FAX: 01482 441141  
email: info@jandcrwood.co.uk • www.metal-craft.co.uk

Issue 1  
20/11/06



View in Horizontal Position

NOT TO SCALE

MODIFICATIONS	04/12	XL 5+ POWER BENDER	
	P/N 1724 replaces P/N 919 P/N 4115 replaces P/N 344 P/N 4131 replaces P/N 352	Part No.732	Version No.1
		 <b>J &amp; C R WOOD</b> HULL ENGLAND	
		DATE: 11/2006	

# XL 5+ POWER BENDER

Please keep these instructions in a safe place for any future reference to the parts diagrams.

## Chapter 1 - Getting Started

### 1.1 Unpack & Assemble Tool Prior to Operation

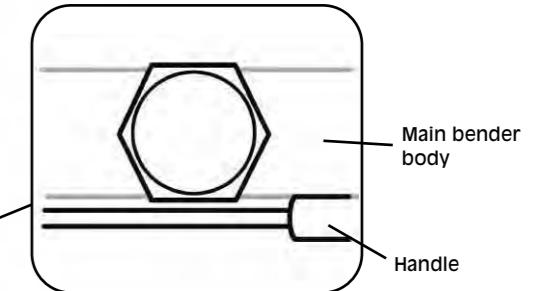
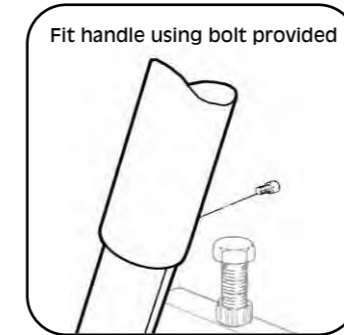

To ensure unhindered operation of handle, adjusting bolt (P/N 983) should be set with the flat faces of the bolt head parallel to the flat faces of the main bender body.

See overleaf for assembly of measuring device

### 1.2 Mounting Tool to a Bench

Fix tool to a strong and heavy bench using 8 x M6 Countersunk Bolts, as indicated.

**A** Fit 4 x bolts via holes visible with tool in upright position

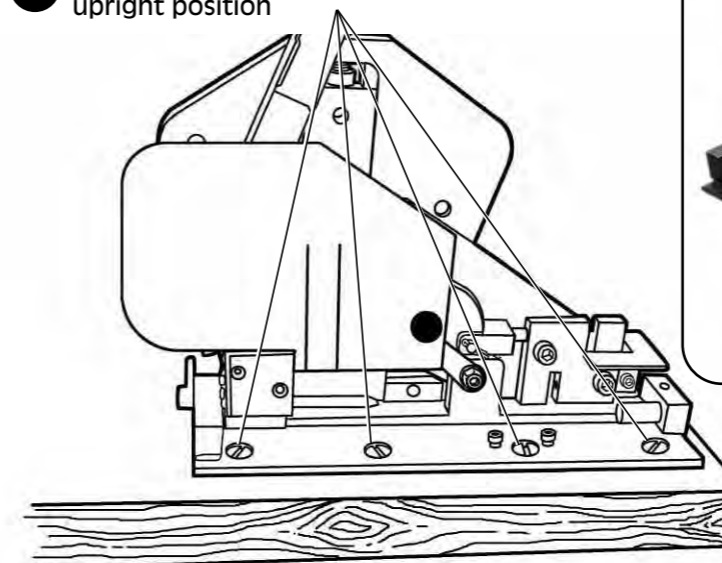

**B** Flip tool into it's horizontal position to fit the other 4 x bolts via holes then visible

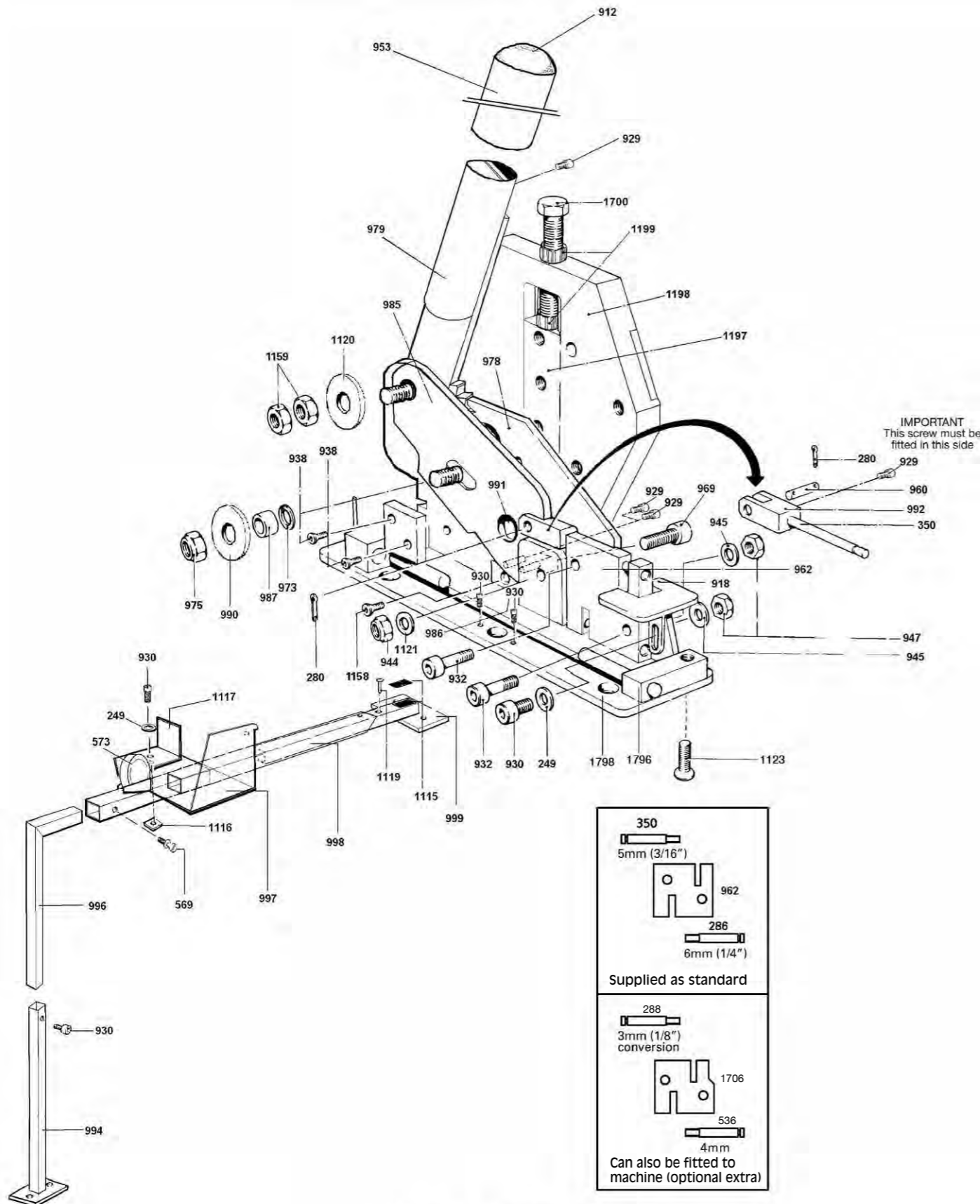
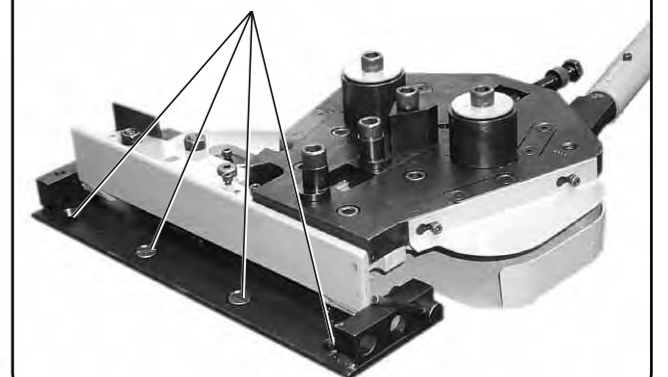

View in Vertical Position

NOT TO SCALE

MODIFICATIONS

	06/09	11/16
P/N 898	replaced by 1197	
P/N 981	replaced by 1198	
P/N 984	replaced by 1199	
P/N 983	replaced by 1700	
P/N 588	replaced by 1123	
P/N 587	replaced by 1796	
P/N 980	replaced by 1798	

XL 5+ POWER BENDER

Part No.732 Version No.1



DATE: 11/2006

**1.3 Assemble Measuring Device**

**a**

**b**

**c**  
For fine calibration of measurements

**d**

a. Attach first part of measuring bar to body of tool using the 2 fixings as illustrated and tighten up with allen key.

b. Slide 'extension bar' over the above and fit the rivet in the aligned holes

c. Slide on tape measure assembly and fit end of tape to magnetic block at the end of bar

d. Fit supporting leg, set to correct height and lock using allen key. The support can be secured to the floor via 2 holes in base for more repetitive use.

-	-	-	-	-	
-	-	-	-	-	
-	16mm (5/8") sq.	30mm x 30mm x 3mm (1.1/4" x 1.1/4" x 1/8") to 25mm x 25mm x 6mm (1" x 1" x 1/4")	30mm x 30mm x 3mm (1.1/4" x 1.1/4" x 1/8") to 25mm x 25mm x 5mm (1" x 1" x 3/16")	40mm x 5mm (1.1/2" x 3/16") to 25mm x 10mm (1" x 3/8")	
-	-	-	-	-	
-	-	-	-	-	
-	-	-	-	-	
-	-	-	-	-	

**1.4 IMPORTANT SAFETY NOTICE - PLEASE READ BEFORE USING TOOL**

A. Safety Guards must be fitted in place and fitted securely at all times during operation of the tool (they should be removed only for routine maintenance/lubrication)

B. Avoid placing fingers in either the entrances or exits of the shearing apertures at all times.

C. Never look down the exit hole of the punch block during operation, as a metal pellet can be expelled at speed. It is therefore recommended that appropriate safety goggles be used

**B.**

**B.**





**C.**

-	-	-	Flat bar on edge	-	-
-	25mm x 25mm (1" x 1")	25mm x 25mm x 1.5mm (1" x 1" x 16 Gauge)	70mm x 5mm (2.3/4" x 3/16") Note Max thickness recommended is 5mm	-	-
-	-	-	70mm x 3mm (2.3/4" x 1/8") Note Max thickness recommended is 3mm	-	-
-	12mm (1/2") sq material before it is heated and tapered	-	-	-	-
-	16mm (5/8") sq material before it is heated and tapered	-	-	-	-
-	-	-	25mm x 3mm (1" x 1/8") to 25mm x 5mm (1" x 3/16") - See Note 5 below	-	-
25mm (1") Dia x 1.6mm (16 Gauge) Wall Thickness	-	-	-	-	-
12mm (1/2") Dia x 1.6mm (16 Gauge) Wall Thickness	-	-	-	-	-
-	-	-	-	18mm x 5mm (3/4" x 3/16") Collar Bar Material	18mm x 5mm (3/4" x 3/16") Collar Bar Material



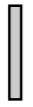

4 Angles up to 60 degrees (approx) can be bent in square material upto 12mm during single pass bending. Angles of 90 degrees can be bent in 12mm to 16mm square material.

5 Max sizes stated for Edge Bending are for use with special bending pillar provided. Larger thicknesses upto 10mm can be bent with care on the Standard machine using the single pass bending head but bars may need to be heated to maintain a flat bend.

## SPECIFICATION FOR XL5+ Power Bender Basic Machine

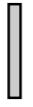
Function	Profile / Size				
Cutting	Max	25mm x 8mm (1" x 5/16") to 40mm x 6mm (1.1/2" x 1/4")	10mm (3/8") sq.	12mm (1/2") Dia	-
Bending (Single Pass)	Max	25mm x 10mm (1" x 3/8") to 40mm x 8mm (1.1/2" x 5/16")	16mm (5/8") sq. - see note 4	16mm (5/8") Dia - see note 4	-
Bending (Progressive)	Max	50mm x 10mm (2" x 3/8") to 40mm x 8mm (1.1/2" x 5/16")	20mm (3/4") sq.	20mm (3/4") Dia	30mm x 30mm x 1.5mm (1.1/4" x 1.1/4" x 16 Gauge) to 25mm x 25mm x 2mm (1" x 1" x 14 Gauge)
Rolling	Max	50mm x 6mm (2" x 1/4") to 40mm x 8mm (1.1/2" x 5/16")	16mm (5/8") sq.	-	-
Punching	Max or or **	5mm (3/16") Dia in 5mm (3/16") thick material 6mm (1/4") Dia in 6mm (1/4") thick material 6mm (1/4") Dia in 6mm (1/4") thick material Requires Optiona extra 3mm Punch Block & Pin (MC285 & MC288)	-	-	-
Punching		Will work with 5mm (3/16"), 6mm (1/4") and 3mm (1/8") rivets (flat or round head)	-	-	-

## SPECIFICATION FOR XL5+ Power Bender with Option Packs

Function	Profile / Size				
<b>Pack 2 - Embossing &amp; End Forging Kit:</b>					
Embossing (Pointed profile to create v's)	Max	-	-	-	-
Embossing (Curved profile to create notches)	Max	-	-	-	25mm x 25mm x 1.5mm (1" x 1" x 16 Gauge)
End Forging Small Pattern	Max	25mm (1") wide material before it is heated and tapered	12mm (1/2") sq material before it is heated and tapered	12mm (1/2") sq material before it is heated and tapered	-
End Forging Large Pattern	Max	40mm (1.1/2") wide material before it is heated and tapered	16mm (5/8") sq material before it is heated and tapered	16mm (5/8") sq material before it is heated and tapered	-
<b>Pack 3 - Edge Bending Kit</b>	Max	-	-	-	-
<b>Pack 4 - Tube/Rod Rolling kit</b>	Max	-	-	20mm (3/4") Dia	-
	Min	-	-	10mm (3/8") Dia	-
<b>Pack 5 - Micro Bending Kit</b>	Max	16mm x 3mm (5/8" x 1/8")	-	-	-

Notes

- 1 These sizes are for Hot Rolled Black Mild Steel Bar & Annealed Bright Mild Steel Bar
- 2 Working beyond the capacities stated above or with materials of greater strength or hardness may reduce the operational life of the machine or its components.
- 3 The above material profiles are for guidance only, the tool may be capable of working with other materials and/or profiles. If in doubt contact J & C R Wood or exercise care when testing the tool on materials or profiles not shown

## 1.5 Routine Maintenance

Ensure all moving parts are lubricated (with oil or grease) at regular intervals.

Avoid a build up of dirt/metal scale in blind threaded holes - clean out regularly.

Check wear plates (P/N 622) regularly for any signs of excessive wear on main part of body (These can be turned over and the reverse side used when necessary).

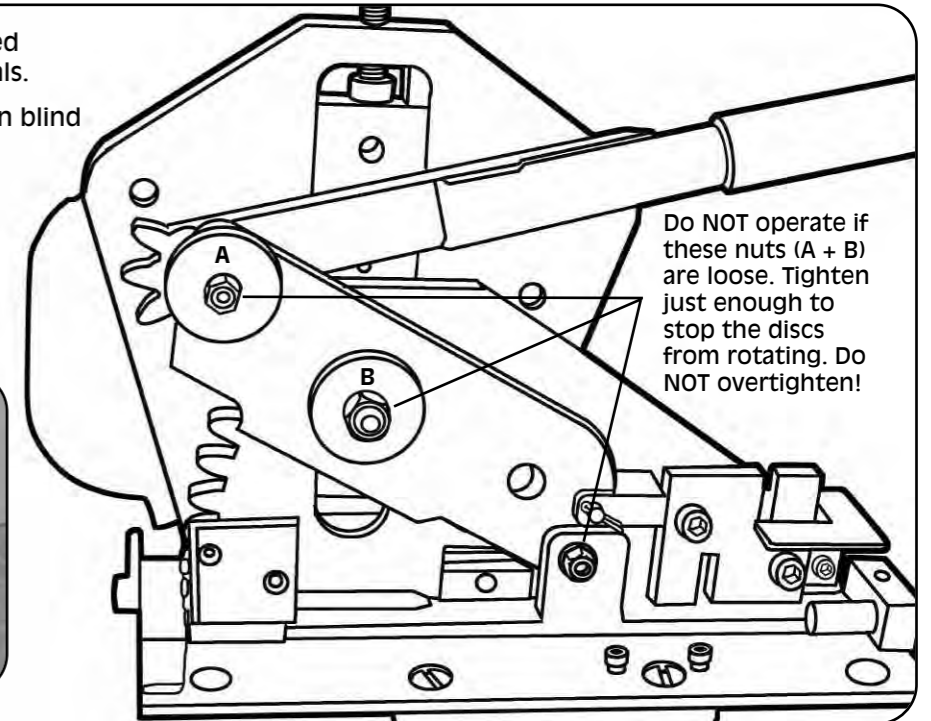
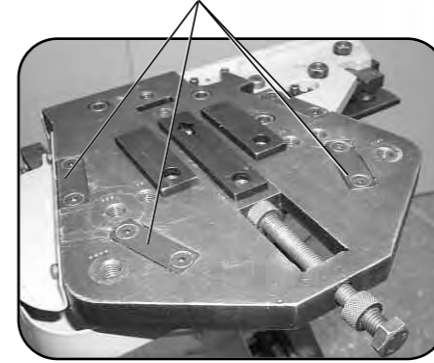

## 1.6 General Operating Notice

When operating the main handle for punching and cutting, ensure that the two adjusting nuts on the adjusting bolt are positioned next to the end of the centre slide and to the underside of the bolt head.

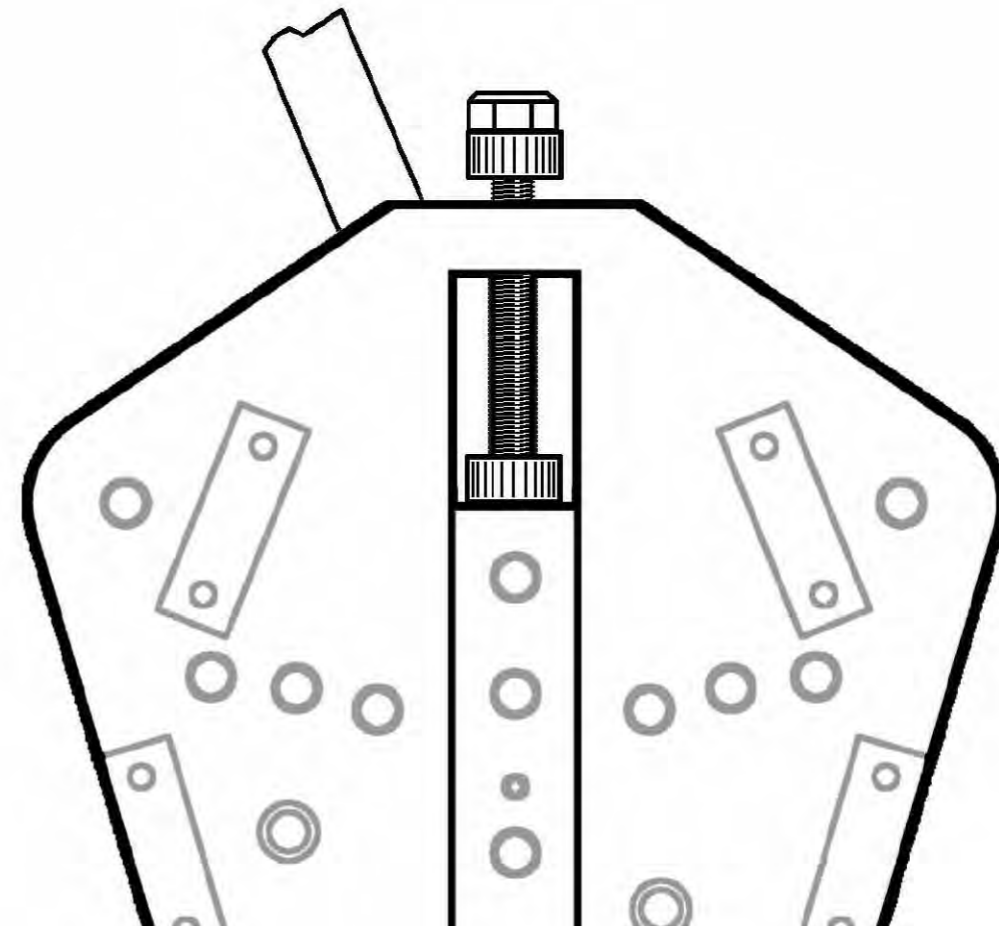

## Chapter 2 - XL 5+ Power Bender Basic Operations

### 2.1 Punching

#### To Punch

The tool is supplied with the reversible punch block fitted as standard. This can be used to punch either 5mm or 6mm holes. To switch, simply remove the block (via 2 fixing bolts) and refit the other way up - remembering to fit the matching punch pin.

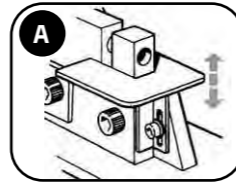
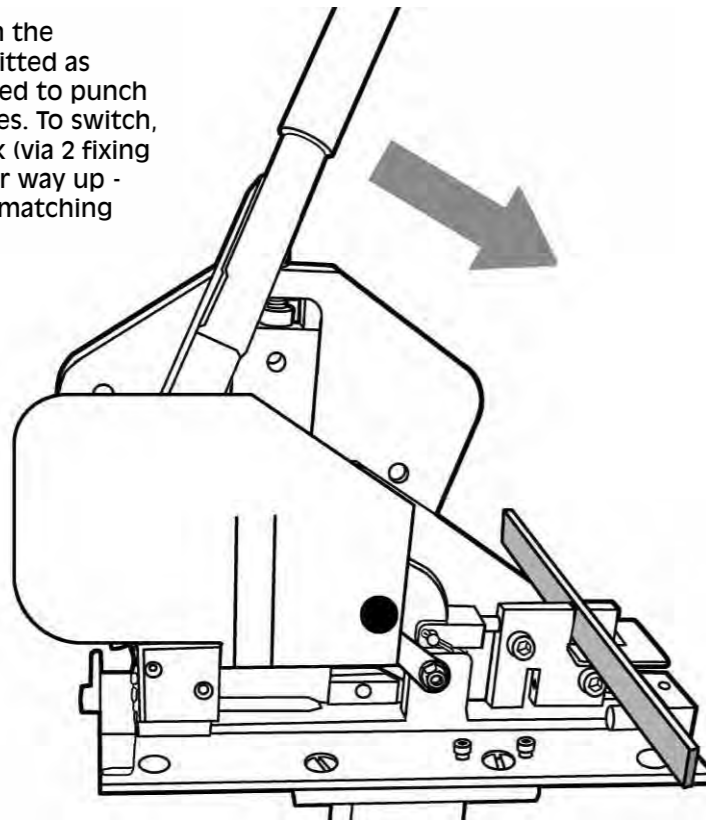
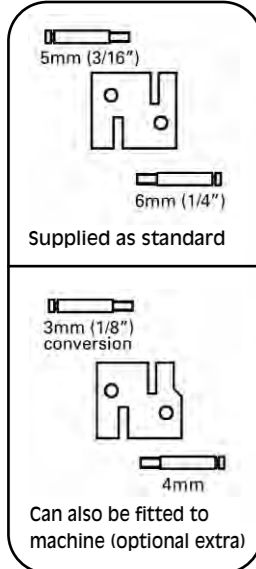

A. Adjustable platform for setting the distances between the hole centre and the edge of the bar.

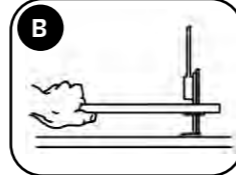

B. It is important to support the metal bar because the large leverage force can break the punch when retracting.

Mark the edge of the metal bar where the hole is to be punched. Place the metal bar so that the mark is in the centre of the slot then pull the handle to punch the hole.

### 3.5 Option Pack 5 - "Micro Bending Kit" (Ideal for creating decorative collars & tight bends)

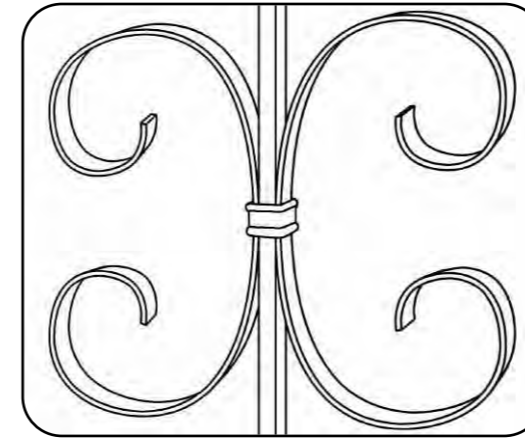

Decorative wrought ironwork often features tightly bent collars made from profiled materials, the purpose of which is to provide a decorative feature and sometimes hide welded or riveted joints. In addition, you may sometimes require very tight bends in flat bar for special components, hooks, etc. The microbending kit provides the means to create these items.

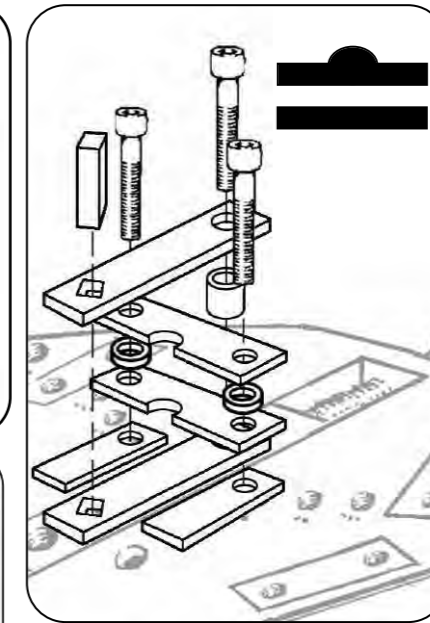

The kit comprises bending platform components which are assembled as shown if bending the profiles shown in the above diagram

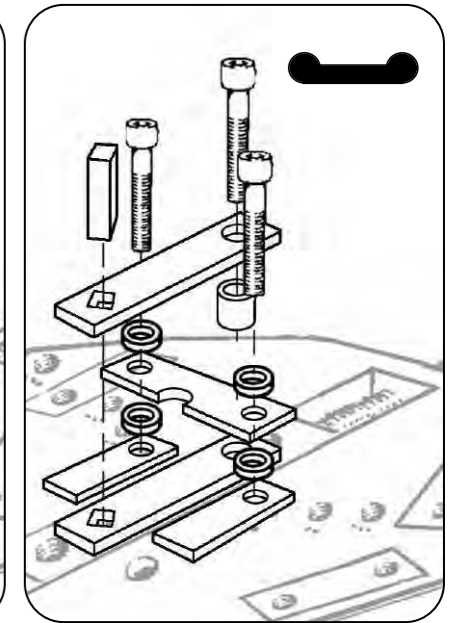

Alternatively, if you wish to bend material with a profile like the one above, arrange bending platform components as shown.

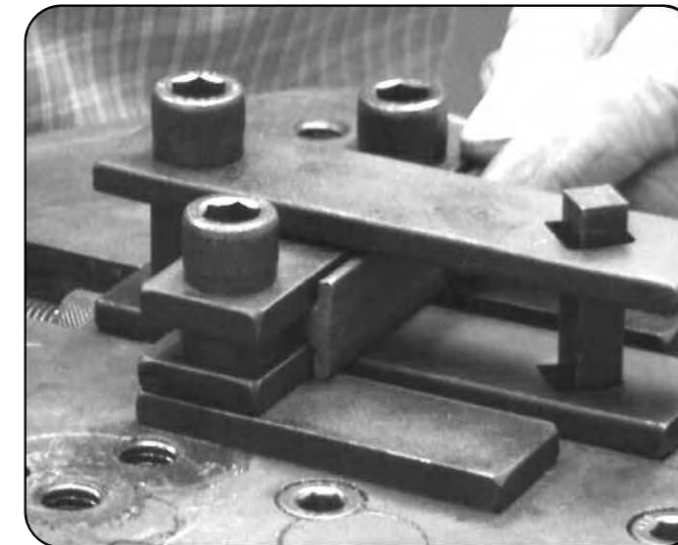

Lock down the various elements, insert the bar as shown here and drop the square micro bending head into position.

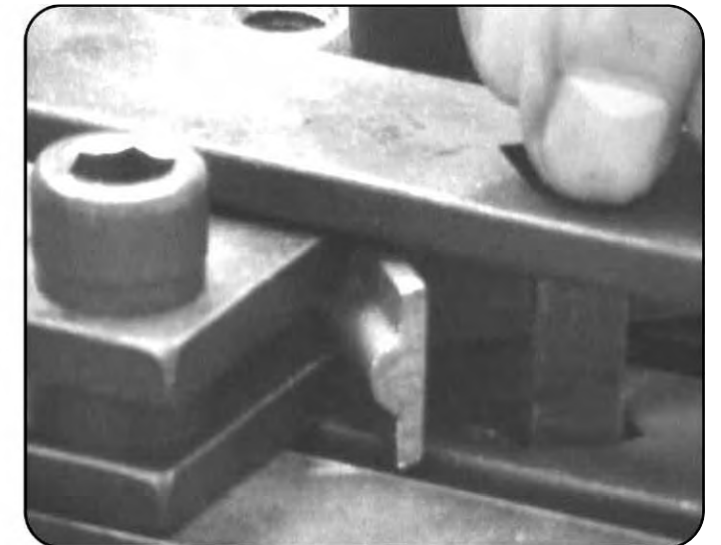

Operate main handle to apply pressure and create first 90 degree bend.

#### USE OF MEASURING DEVICE

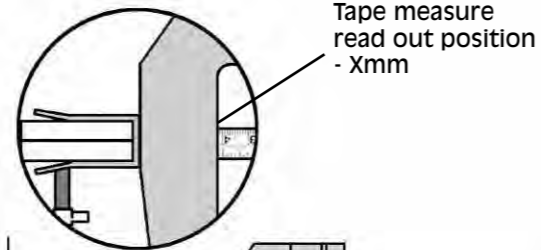

Tape measure read out position - Xmm

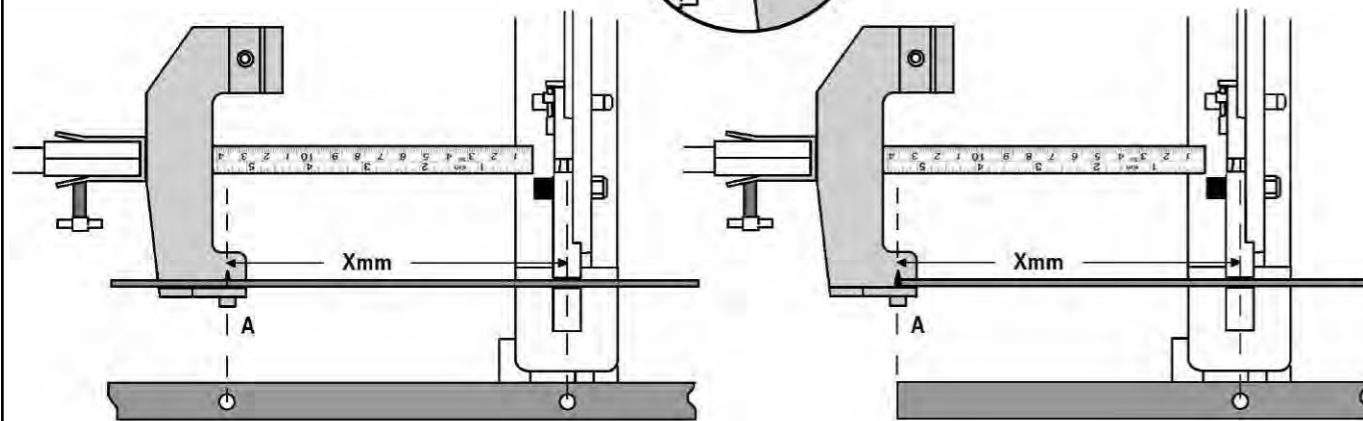

CENTRE TO CENTRE

EDGE TO CENTRE

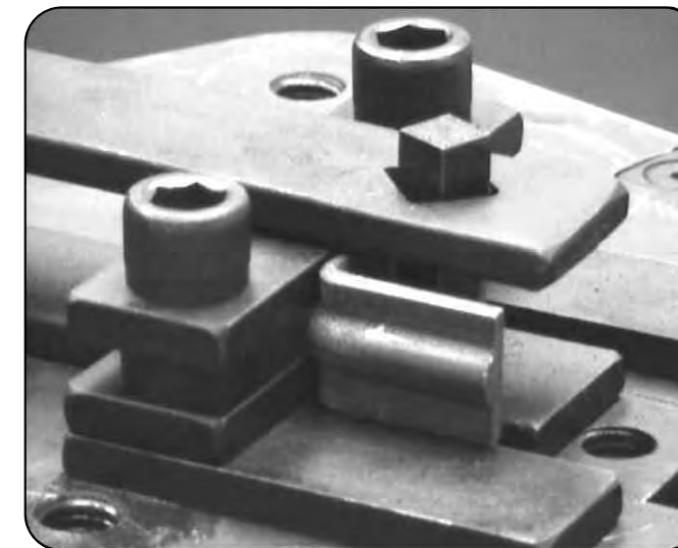

Back off the handle to release and move material around in readiness to repeat the second bend.

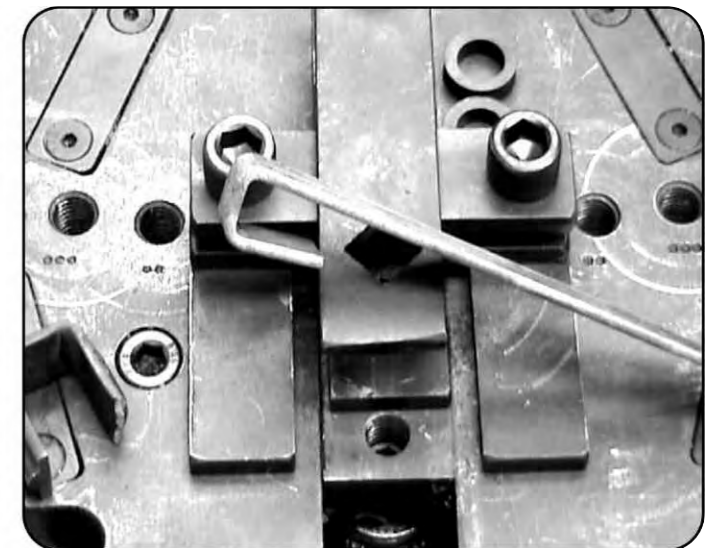

Right angle bends can thus be created with as little as 12mm between them (in this case using simple flat bar).

### 3.4 Option Pack 4 - "Tube/Rod Rolling Kit

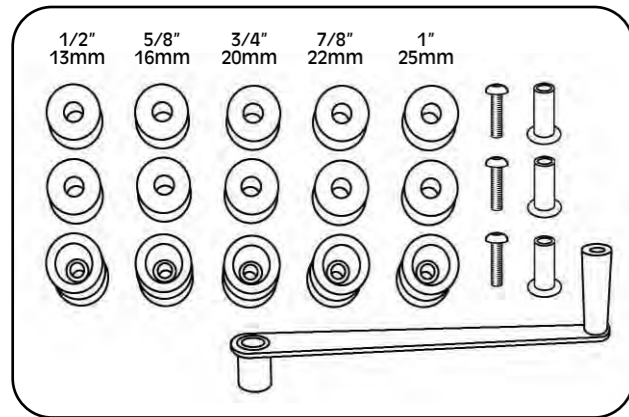

The Tube/Rod Rolling kit comprises a special winding handle and 5 sets of tube/rod rolling rollers (with inner sleeves) to cover these five tube diameters (shown above). Each set comprises 2 slave rollers (to be fitted in side pillar positions) and one drive roller which fits to the centre slide and is driven by the winding handle.

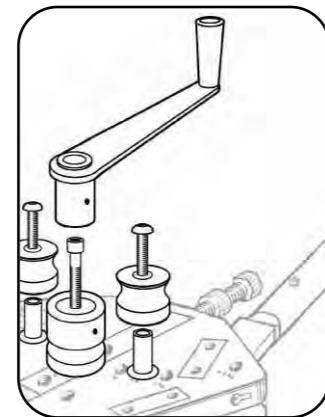

Fit drive roller in position shown on centre slide. Side rollers are positioned according to size of tube and fixed in position using button head screws. Position 2 is for smaller tube/rod sizes (starting from 13mm) with position 3 being used for tube/rod sizes approaching 25mm diameter. Before starting, make sure all rollers and sleeves are well lubricated with grease or oil.

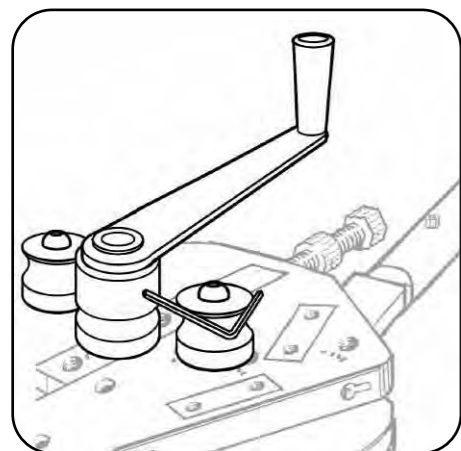
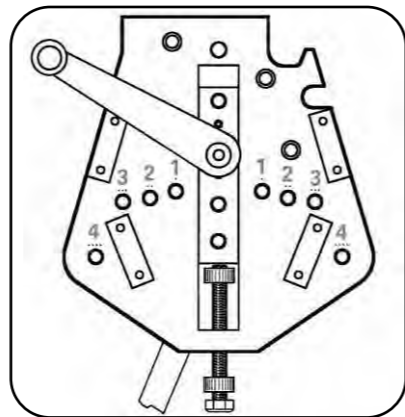

After fixing the drive roller on the centre slide, locate the winding handle and align grub screw on the drive roller with hole in winding handle capstan before tightening grub screw to lock handle in position.



Before commencing rolling, ensure round tube or rod is clear of all grease, oil or dirt to ensure rollers grip properly during rolling. As with conventional rolling, apply a little pressure with the main handle and use the adjusting nut to keep that pressure on, thus allowing you to use a hand to operate the winding handle and the other hand to guide the tube to keep it horizontal i.e. prevent the ends of the tube dropping under gravity.



Drive the tube/rod through the rollers and when you get to the end of the tube/rod, apply a little more pressure and drive it back in the opposite direction. Repeat this process patiently and avoid temptation to apply too much pressure to cut down on the number of passes.



It is possible to create tight curves and even complete circles.



If you wish to form a complete circle, to avoid a flat section (from each end), manipulate the rod/tube so that ends



Rolling with the machine set in the upright position means that both hands can be used as gravity doesn't make the ends drop out of line.

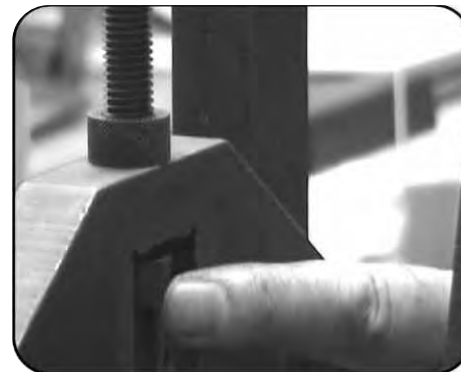

By using the adjusting nut it is possible to roll identical circles time and again.



When completed, slacken off the adjusting nut to release finished rolled curve or circle.

### 2.2 Cutting

#### SHEARING FLAT BAR

A. The bottom small blade is reversible having four cutting edges. Also note the two adjusting screws to maintain quality of cut.  
B. Crop corners of metal bar for a professional finish when producing decorative wrought ironwork.

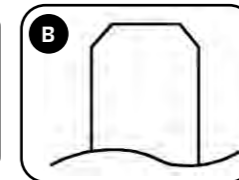
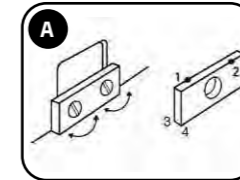

N.B. When cutting long bars it is useful to create your own trestle table/support arrangement to support the weight of the bar on the input side.

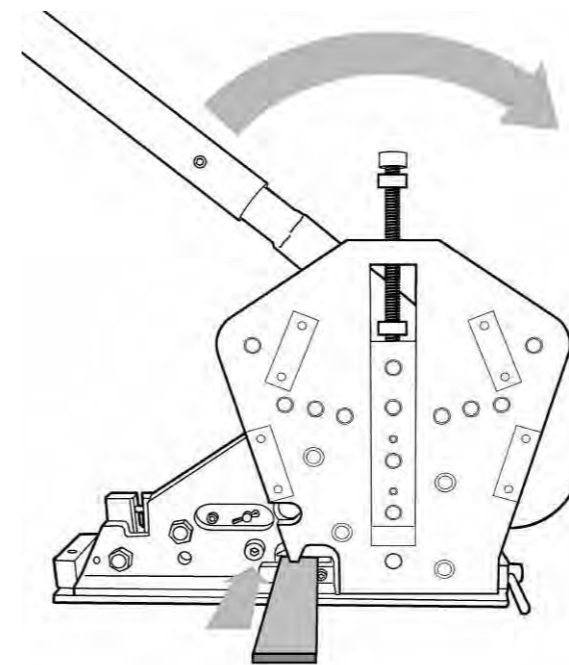

#### SHEARING SQUARE OR ROUND BAR

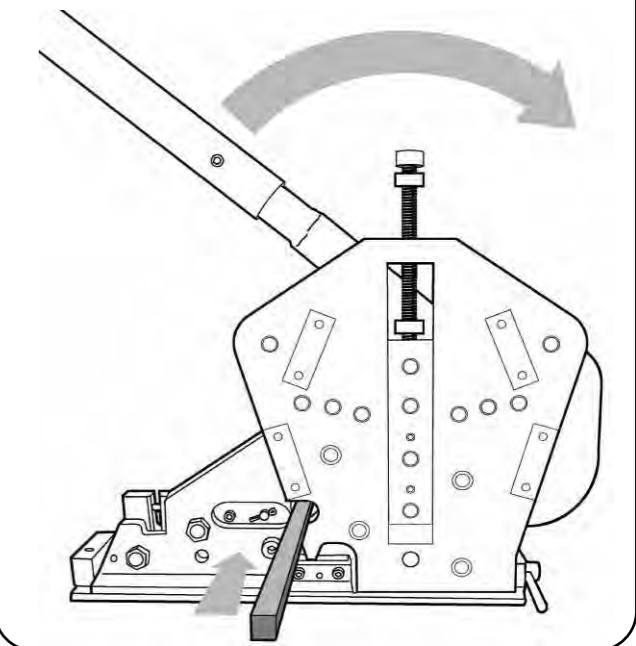

#### USE OF MEASURING DEVICE

Before using measuring device for shearing, please check for accuracy and make a minor adjustment if necessary via the adjustable 'stop' plate.

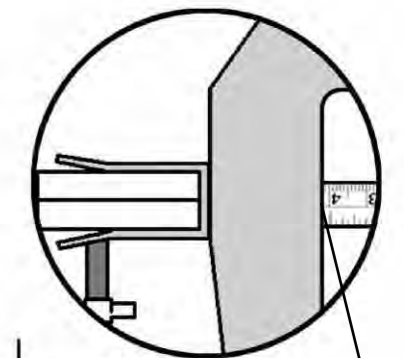
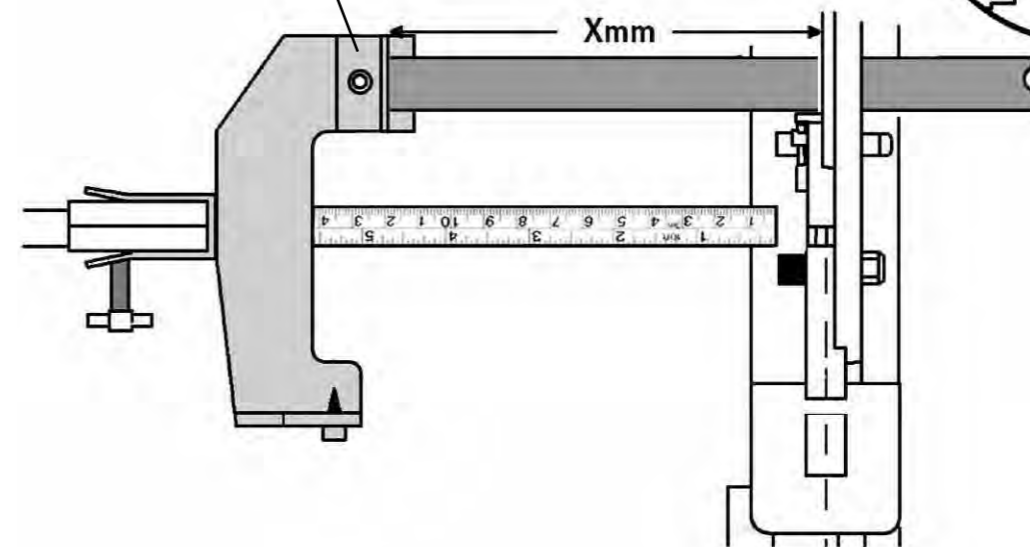

Tape measure read out position - Xmm

### 2.3 Riveting

Drop the body of the tool into it's horizontal position for riveting

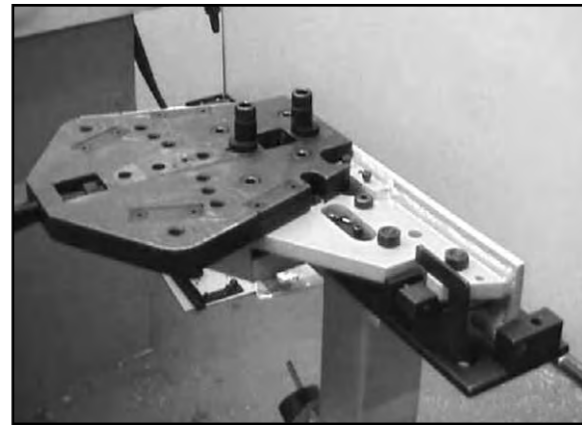
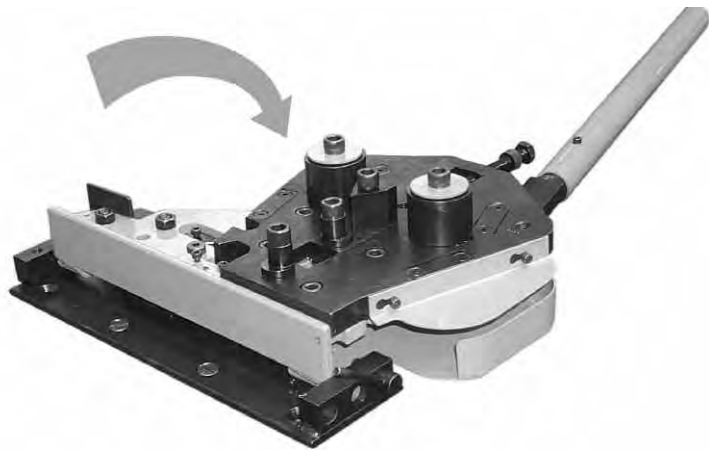

Prior to Riveting, remove all items from the top face i.e side pillars, the angle former and/or winding handle to leave just two rivet posts - this allows large panels to be riveted without obstruction.

Place the metal scrolls/bars ready punched with rivet in place, between the posts. Push the lever in the direction shown to close the rivet, using the minimum amount of pressure necessary. Do not attempt to close the rivet in one go. This can cause damage to the machine. Instead, rivet as indicated (inset).

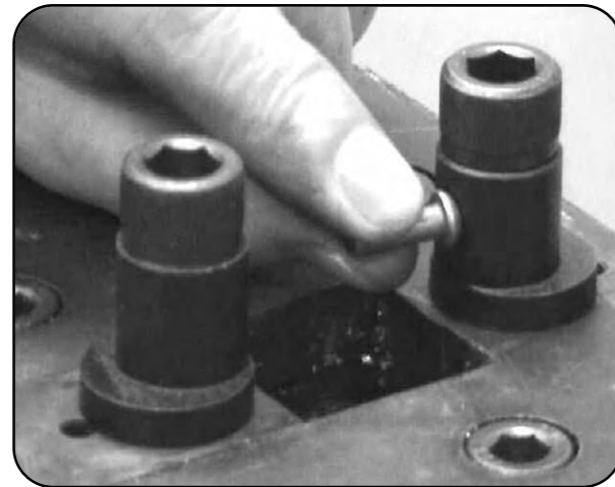
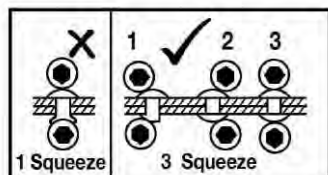
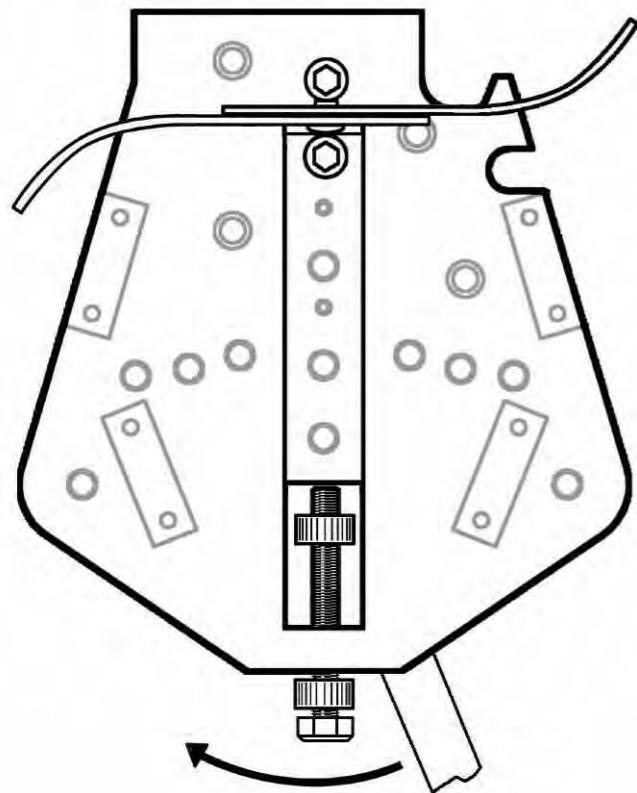

Note - there is a dimple in one of the riveting posts - when riveting bars together using round headed rivets, place the head of the rivet into this recess to prevent slipping. It is also possible to use this 'dimple' to round off the other end of the rivet by positioning it the other way round.

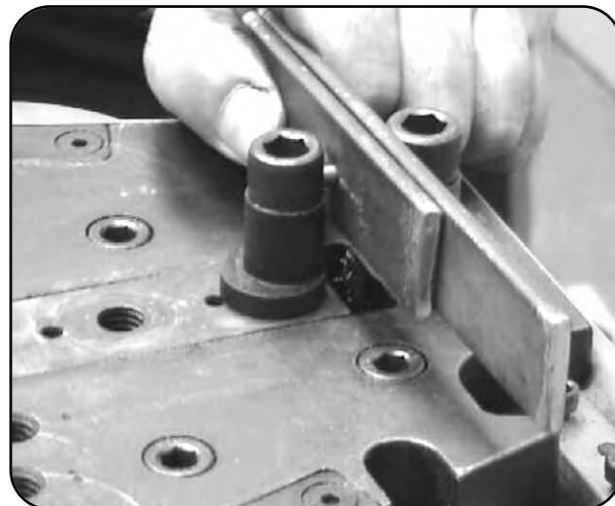

If using flat head rivets, squeeze higher up between the cap screw heads.

### 3.3 Option Pack 3 - "Edge Bending" Kit

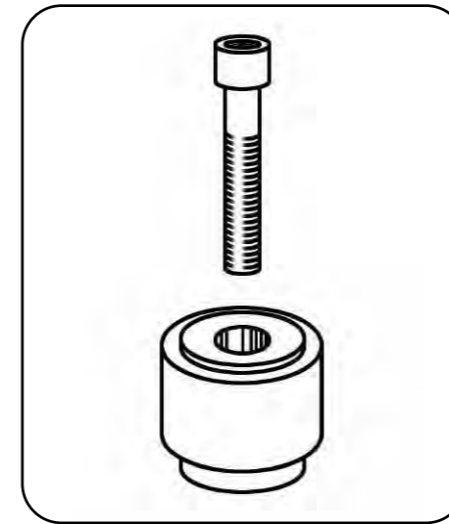

The Edge Bending kit, comprises a reversible bending pillar and fixing bolt. The bending pillar has a 3mm and 5mm recess machined at either end to enable bending of 3mm or 5mm thick material on edge in a single pass

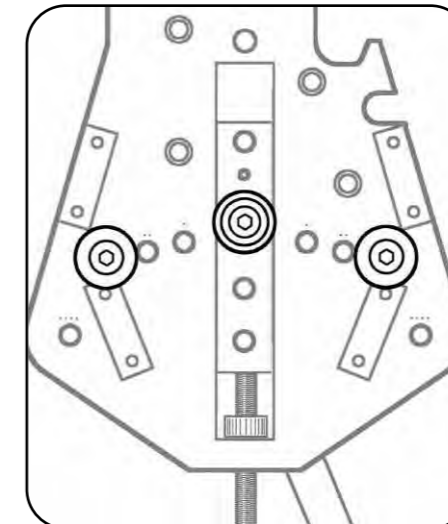

Locate and bolt down the Edge Bending pillar in the appropriate hole in the centre side, as shown. The side pillars used for conventional bending should be located in the most appropriate position according to thickness and width (ref: below).

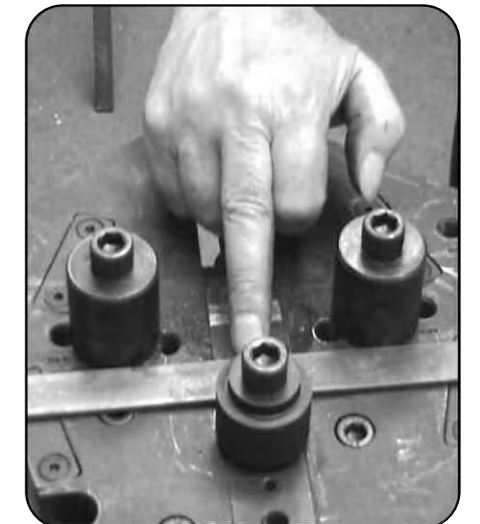

To bend 3mm bars (up to 20mm wide) fix the edge bending pillar with the shallower 3mm recess at the bottom and fix the side pillars in position 2. Beyond 20mm and up to 25 mm move the side pillars to Position 3.

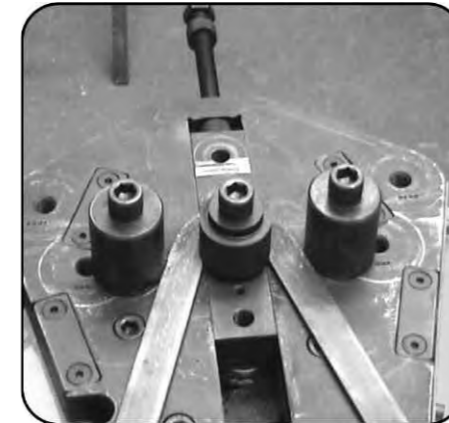

The flat bar can now be bent 'on edge' to an angle of 60° or less (if 3mm thick). To get a tighter angle still, you can always place the shims (provided as standard for conventional bending) over the side pillars.

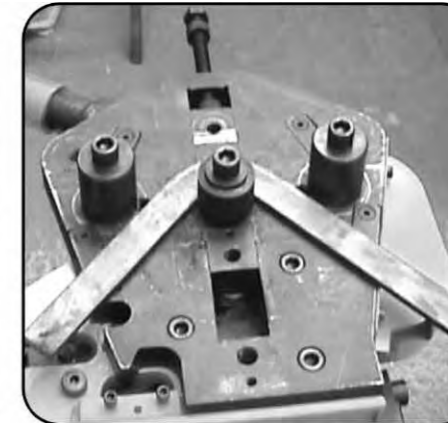

For bars between 3mm and 5mm, use the edge bending pillar with the larger recess at the bottom and fix the side pillars into position 3 to achieve angles just beyond 90 degrees.

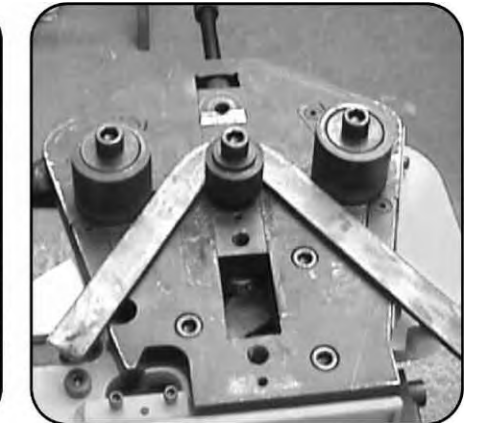

Again, by placing shims over the side pillars tighter angles approaching 60 degrees can be achieved.

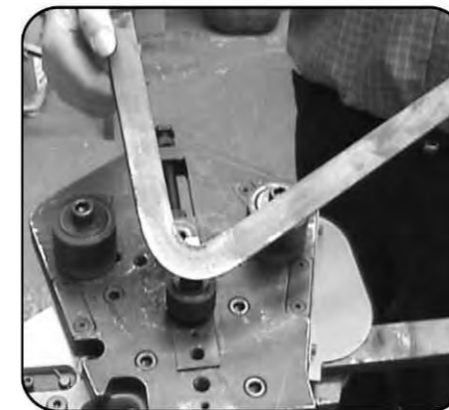

As shown here, this optional extra produces impressive results when bending on edge, making it useful for producing frames and other useful components. Repeated bends can be achieved through the use of the adjusting nut to create an end stop as shown in section 2.5A.



To bend even heavier gauge metal - from 6mm to 10mm it will be necessary to revert to the standard triangular bending head. Because of the thickness of material the bar should hopefully remain flat when bending. However, if it doesn't, to overcome this the bar may need to be heated up first to soften it.

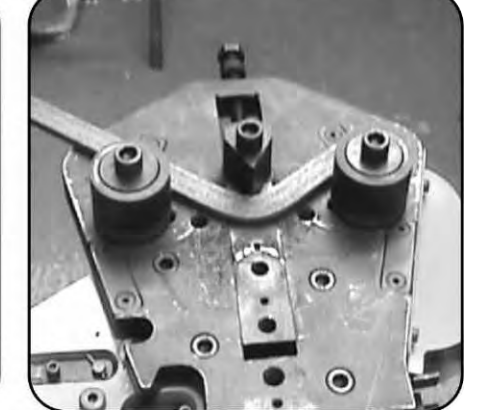

Again, bending angles can be increased by using the shims over the side pillars.

### 3.2b End Forging (using heated bar)

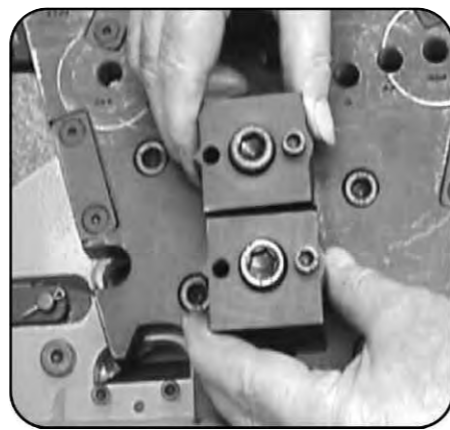
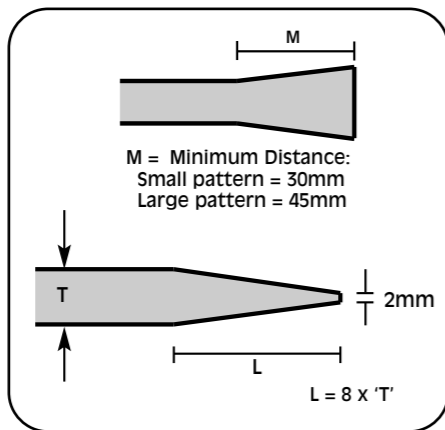
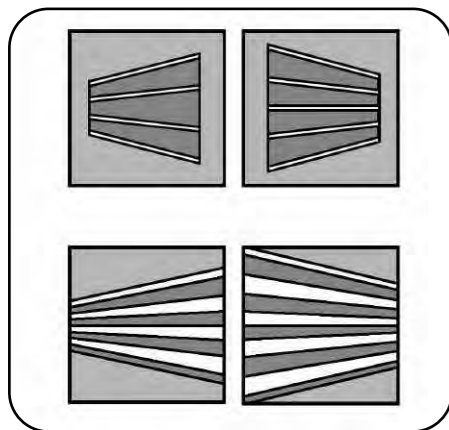

The Embossing/End Forging blocks each have two different end forging patterns for creating a decorative crimped effect on the hammered ends of bars to create attractive "fish tailed ends" for use in the centre of scrolls or as a decorative feature on the end of flat, square and round bars. There is a small pattern for metal bars up to 20mm wide, and a large pattern for metal bars from 25mm to 35 mm wide.

To create the blanks prior to end forging, we recommend heating the end of bar(s) using a forge or an oxy-propane torch and hammering out the taper on an anvil as per the guidance drawing above. The length of the taper in all cases needs to be at least equal to the length of the fluted pattern that you use on the forge blocks (small pattern = 30mm; large pattern = 45mm).

Align the matching male/female faces of the embossing/end forging blocks and locate in appropriate holes on bender body and centre slide as shown. Note - the blocks in this orientation do not have a rear locking bolt as the blocks do need to rotate a little to accommodate the taper on the bar.

If you are going to scroll the forged end in the Metalcraft Mk 3/4 Scroll Former then the length of the taper should be at least 8 x the thickness of the bar. For all other applications you can make the taper length 5 x the thickness. The tip of the flattened end needs to be 2 - 3mm thick.

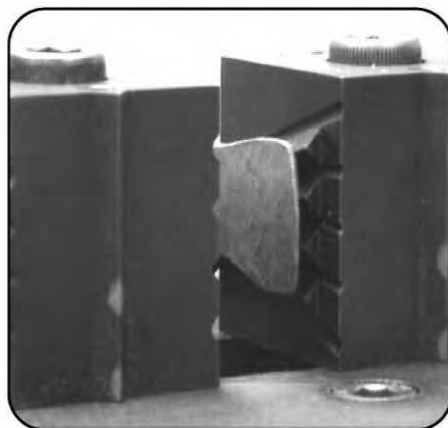
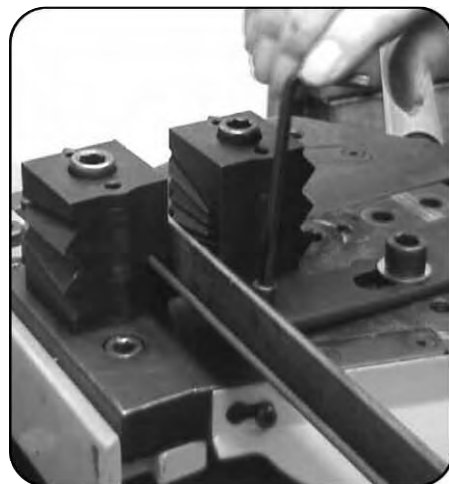

Next fit one of the guide rails to the bender body, and use the height adjustment to ensure the heated and tapered bar is properly aligned to the fish tail pattern on the block as shown above. Note, when placing the heated tapered bar between blocks it is important that the end of the bar lines up with the end of the fluted forging pattern on the block

Heat the 'swollen' end of the bar until it is glowing 'red hot'.



It is very important to have the heat source as close as possible to the tool to ensure there is minimum loss of heat.

Insert the heated end as instructed and operate main handle to squeeze the end of the bar between the blocks to forge end.

The end result is a very stylish fish tailed end, which can be produced on the end of flat, square or round bars.

### 2.4 Rolling

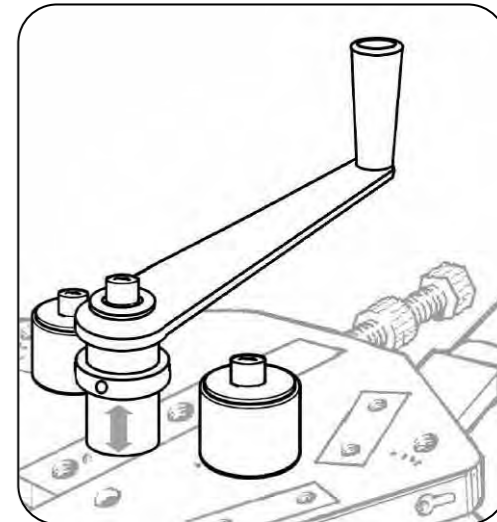
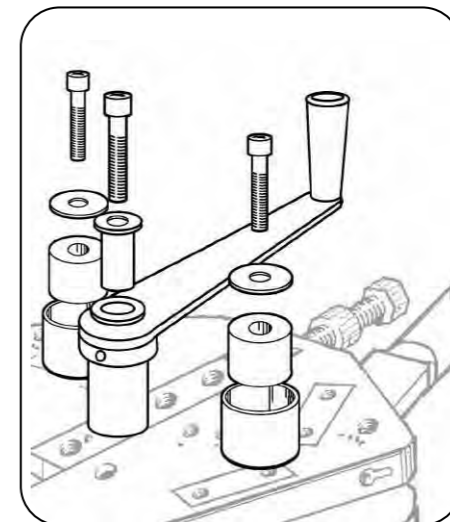
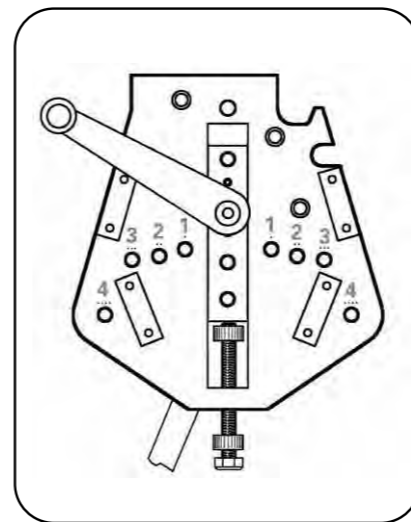

The above diagram is provided for approximate guidance on the best position of the side pillars depending on the gauge of the metal bar being rolled. Position 1 is for thinner materials from 2mm, Position 3 for heavier bar up to 16mm, with Position 2 covering materials midway between these two extremes. If rolling proves difficult at one side pillar position, try rolling with the pillars at a wider position if possible

Once position of side pillars selected, fit side pillars and outer shims and lock down tightly with top washers in place. Finally fit winding handle into correct hole on centre slide as indicated.

Height of sleeve on capstan of winding handle should be adjusted (using allen key) to suit thickness of bar to be rolled. This is to prevent any vertical movement during operation.

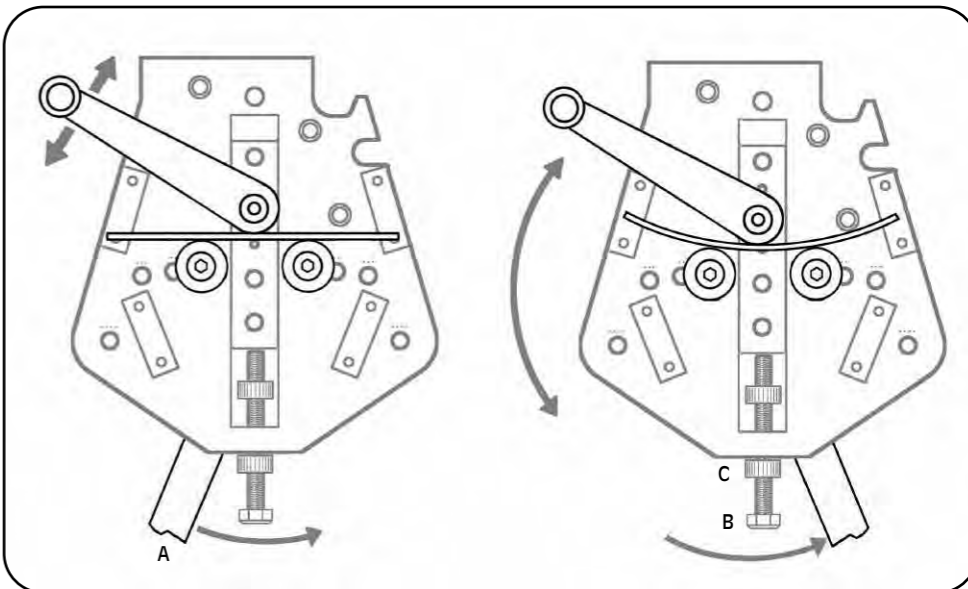

Open the space between the rollers by means of lever 'A'. Place metal bar between the rollers and apply slight pressure with lever 'A' (maintain pressure by tightening adjusting nut 'C').

Rotate rolling handle to drive the metal bar through the machine. This will produce a curve. By applying more pressure and rotating handle in reverse direction, the metal bar will return back through the rollers and produce more curvature. Screwstop 'C' can be used to maintain the applied pressure, thereby allowing both hands to be used for operating the winding handle.

By repeating this it is possible to produce an infinite number of curves and circles.

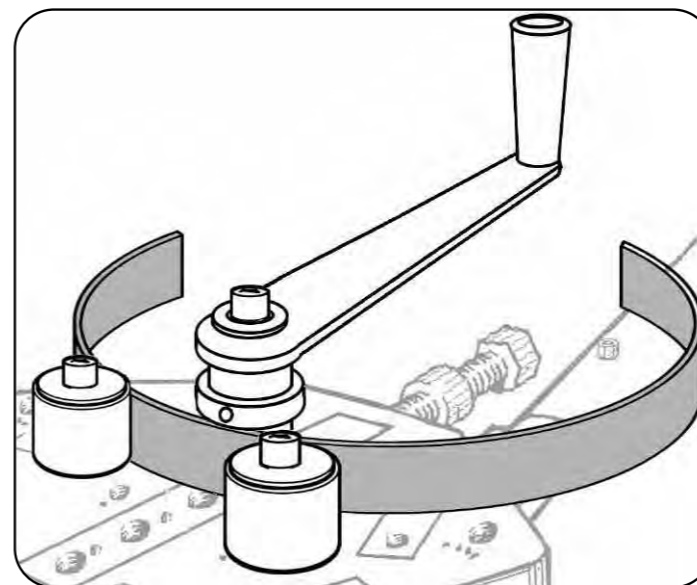

If preferred, the winding handle can be fitted to the centre slide on the opposing side of the two side rollers.

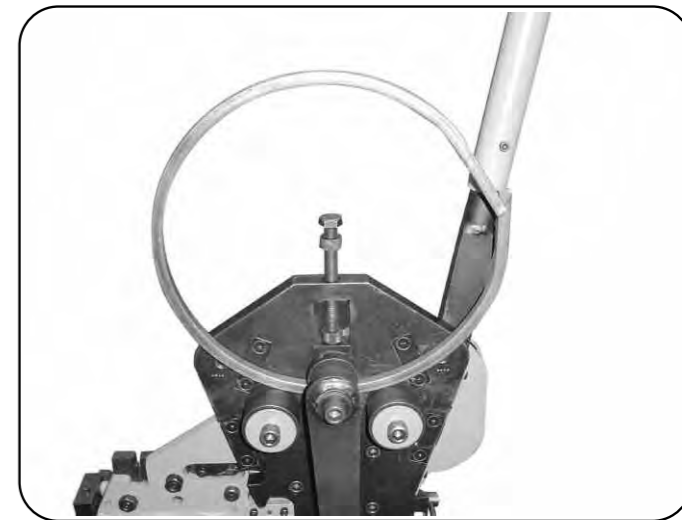

If preferred, rolling can be carried out with the tool in the vertical position - in certain cases operators may find it easier to roll bars with the tool in this position.

## 2.5a Single Pass Bending

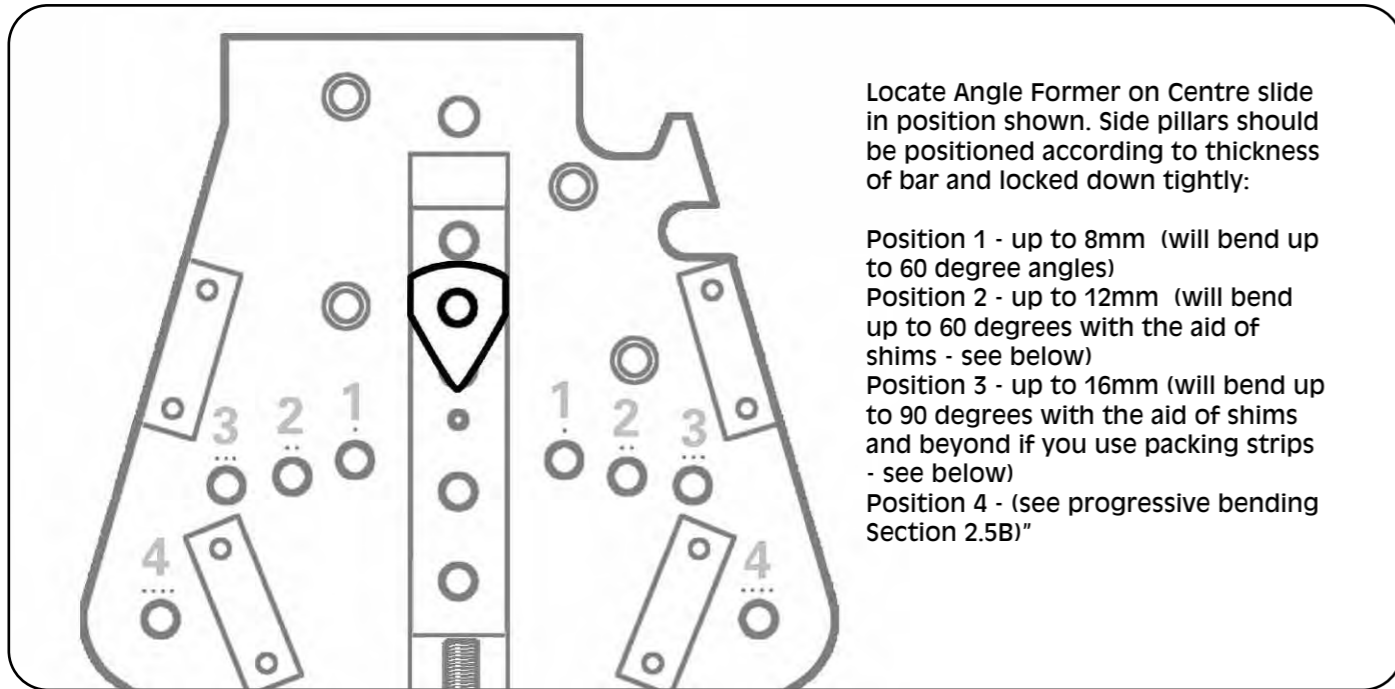

In position 1 it is possible to create bends as tight as 60° in one pass

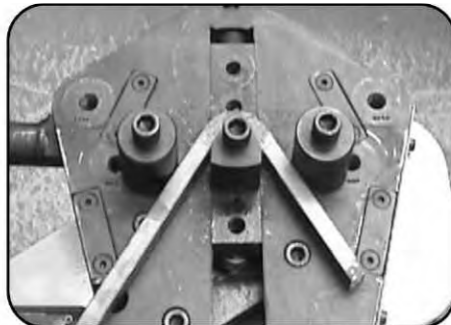

To achieve tighter bends in position 2, bend bar as far as possible then add the 'shims' over the 2 side pillars and bend again

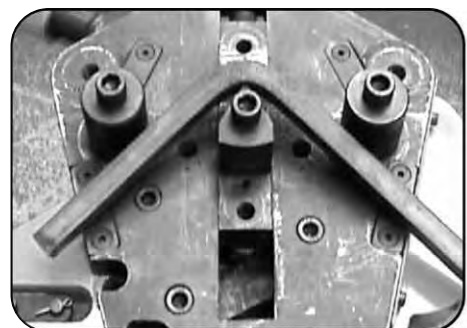
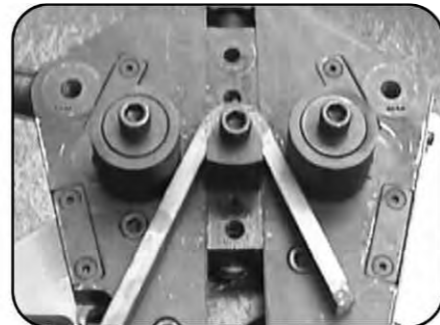

For heavier bar in position 3, bend to maximum with side pillars then add 'shims' and repeat.

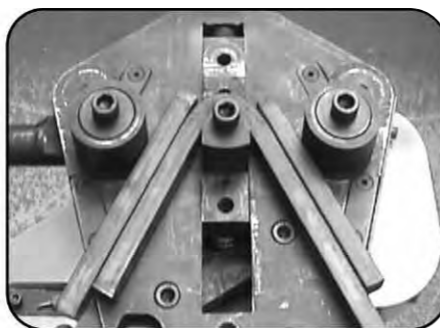
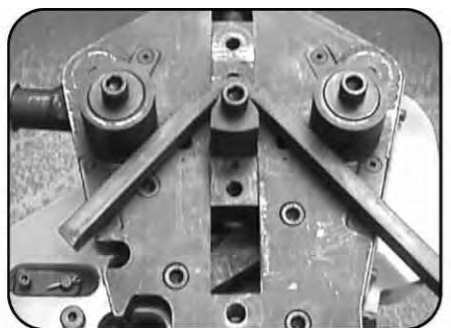

For even tighter bends, add some off-cuts of bar as packing and repeat

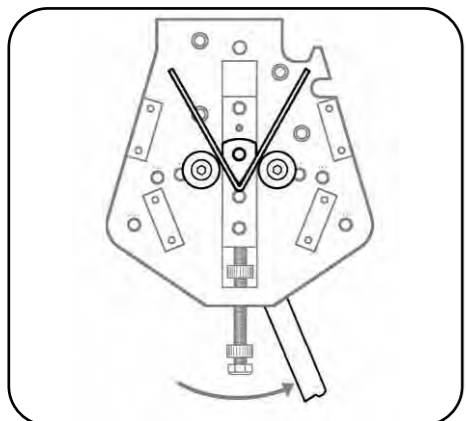

To bend a particular angle repeatedly, first create initial bend.

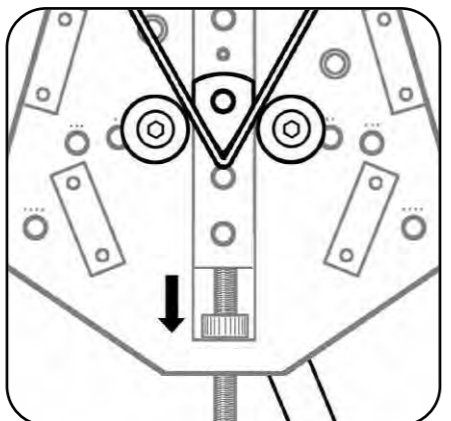

Maintain handle at end of travel, and rotate adjusting nut towards bolt head of adjusting screw until stops at end of slot and touched the bender body.

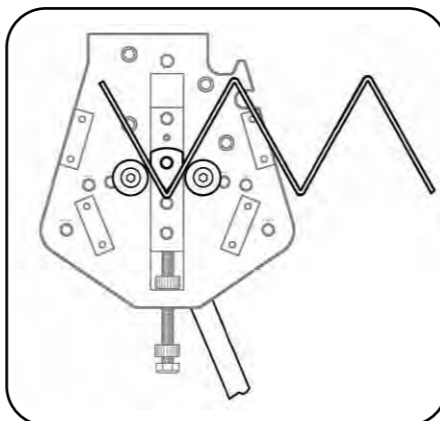

The adjusting nut forms an end stop to ensure consistent repeatable angles can be bent.

## 3.2 Option Pack 2 - Embossing & End Forging Kit

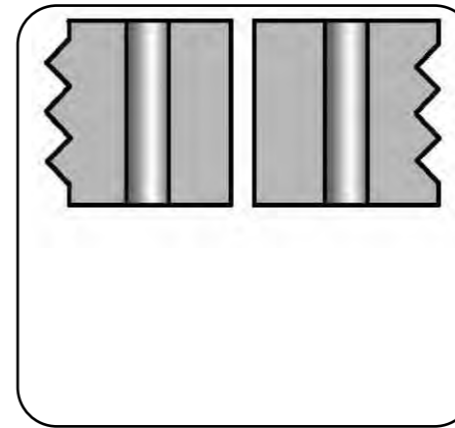

The Embossing & End Forging kit comprises 2 x Embossing/End Forging Blocks plus two guide rails.

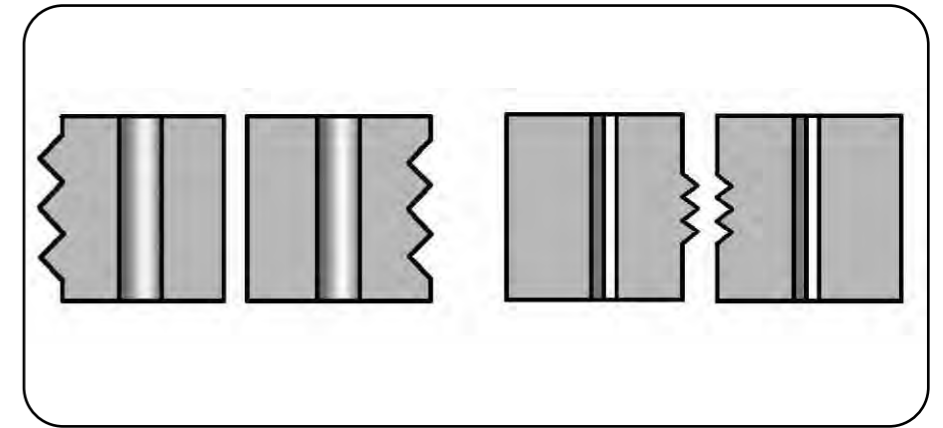

The Embossing/End Forging blocks each have two different embossing patterns for creating decorative effects in bars and tubes. This operation is performed cold i.e. without the need to heat the bar. The pointed faces put distinct v's or nicks into the edges of flat bar, on the faces of square tube, or on corners of square bar. The curved faces put more gradual curved notches in the edge of flat bars and the face of tubes to give a hammered effect.

### 3.2a (Cold) Embossing

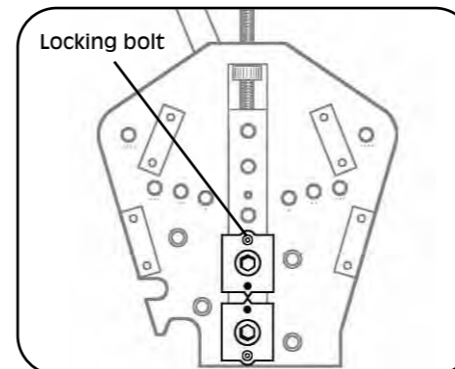

To create nicks in the edge of bars, locate blocks as shown above and ensure both points on the matching faces line up before tightening. Make sure rear locking bolt is also tightened to prevent blocks from twisting during embossing.

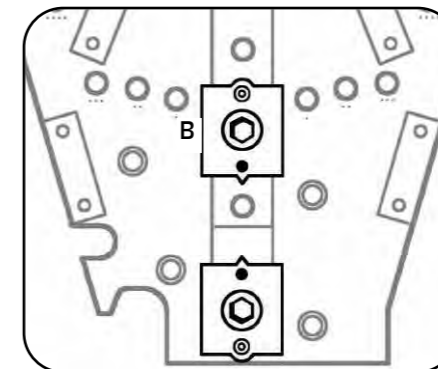

NOTE: For wider material locate block on centre slide in second position (B) as shown here.

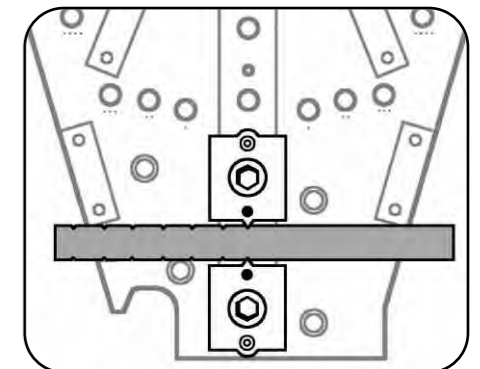

Feed the bar through the tool and operate main handle to create decorative indent pattern in the edge of the bar to suit.

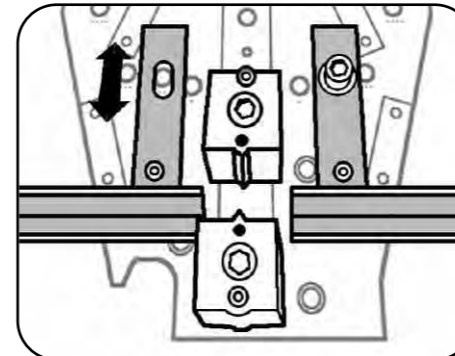

If you want to place decorative nicks on the corners of square bar or tube, fit and align guide rails carefully to ensure bar is centralised between two faces.

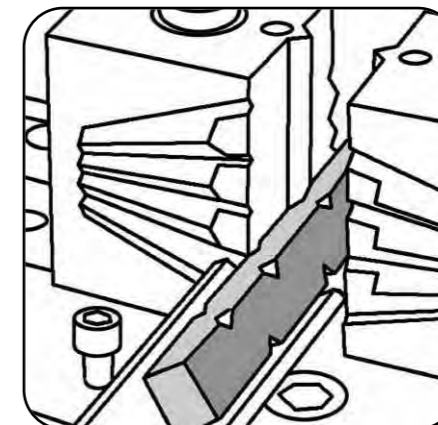

Again, feed bar in section by section to create a stylish embossing pattern on square bars.

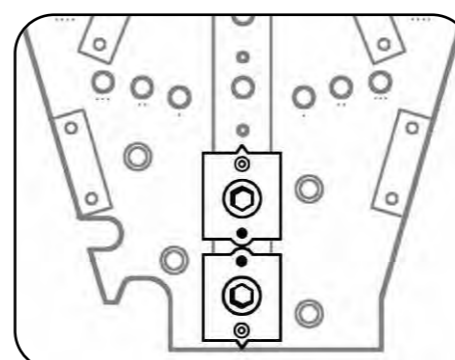

To create gradual curved notches in the edges of bar (or the faces of square tube) locate blocks and fix as shown.

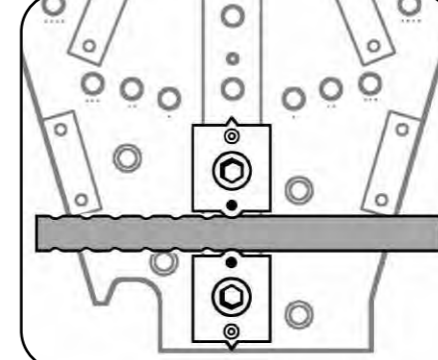

Again feed the bar through the tool and operate main handle to create decorative notch pattern in the edge of the bar to suit.



Applying gentle curved indents down the length of the tube achieves a decorative hammered effect.

### 3.1 Option Pack 1 - The Pedestal

#### THE OPTIMUM MOUNTING SOLUTION

To get the Optimum use out of your XL5+ Power Bender, we strongly recommend our floor mounted pedestal. Due to the high forces generated during some operations of this tool, a sturdy and stable platform is essential. Our purpose built pedestal offers this when firmly anchored to a concrete (or similar) floor. It also offers all-round accessibility when operating the tool when compared to a bench mounted tool.

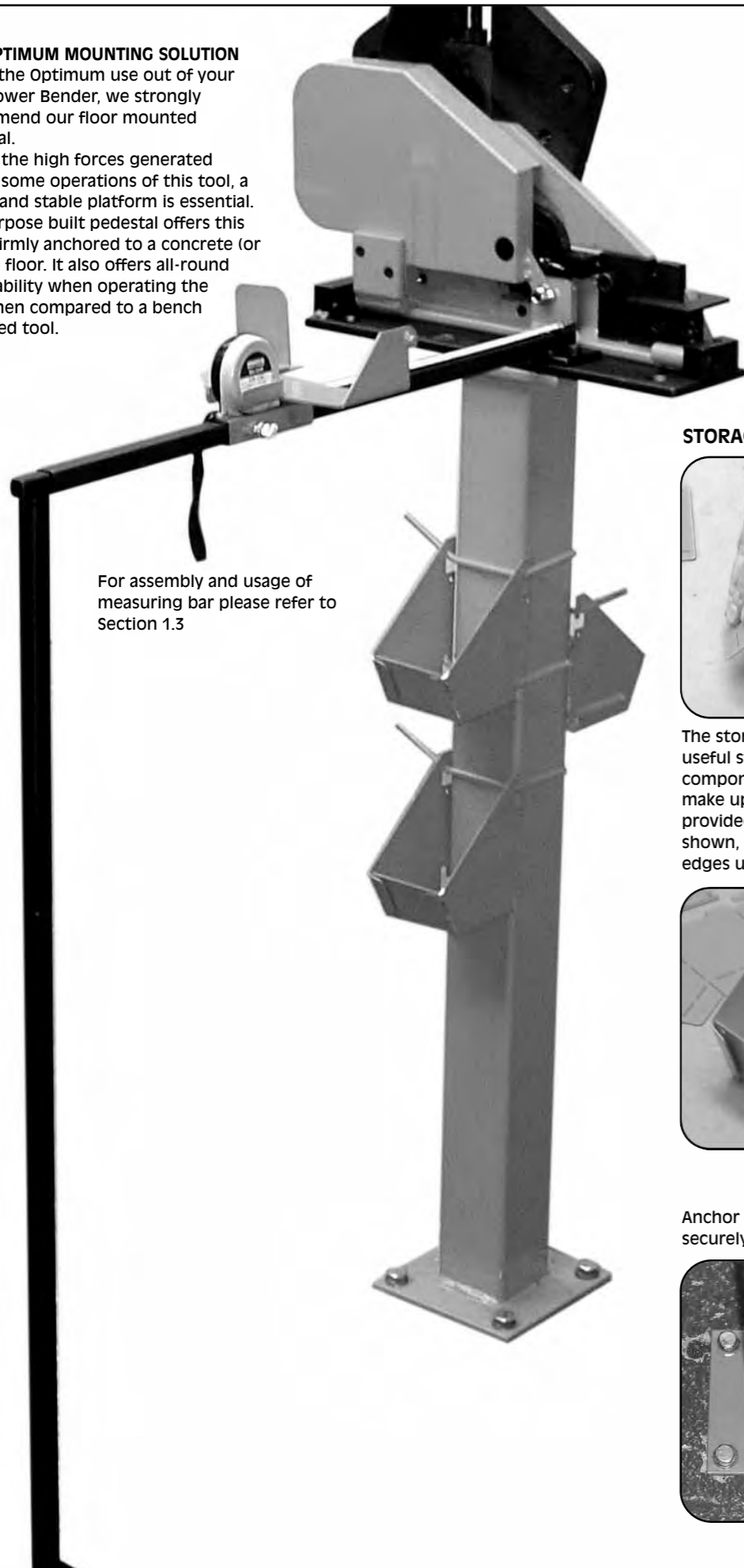

For assembly and usage of measuring bar please refer to Section 1.3

#### STORAGE BINS



The storage bins provided are useful storage for unused components and spare parts. To make up from flat blanks provided, simply fold the bins, as shown, along the perforated edges using a firm worktop.



Anchor base to solid floor securely with 4 heavy duty bolts.



### 2.5b Progressive Bending

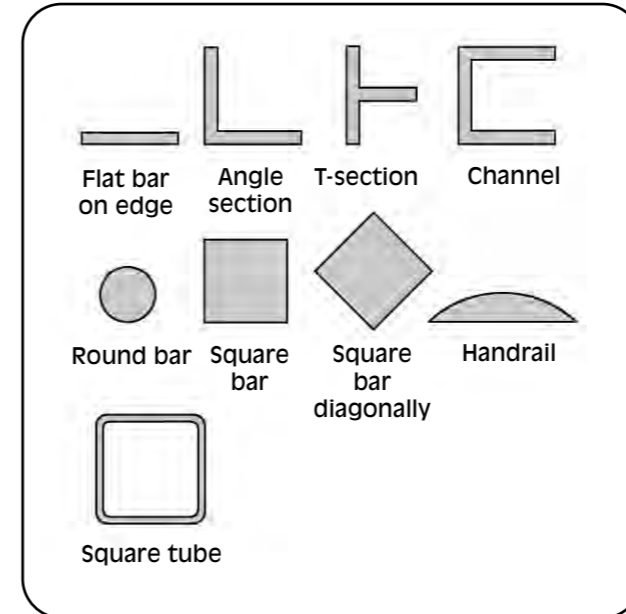

Progressive Bending can be used to create curves on materials with cross sections that cannot be rolled with the rolling method in section 2.4. Good results can be achieved using a wide variety of sections as shown here.

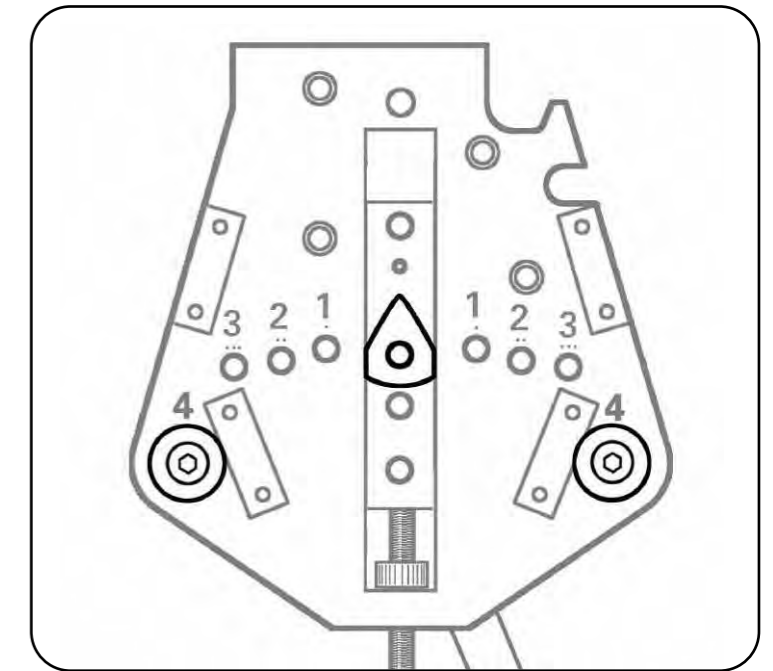

For progressive bending, fit side pillars in Position 4 and fit angle former with curved side facing pillars in position shown.

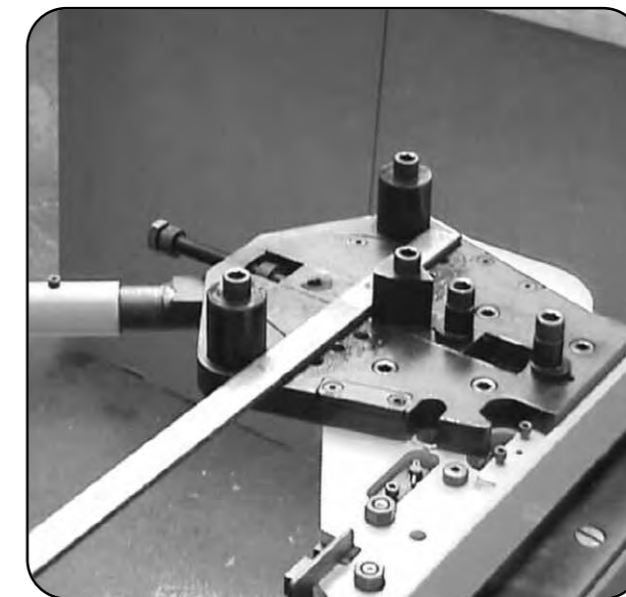

Place bar to be progressively bent in machine as shown and operate handle to make first bend.

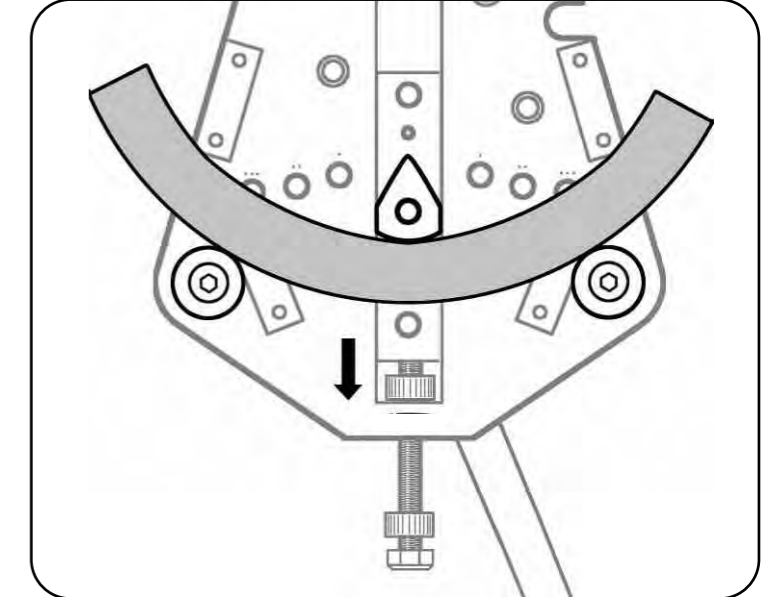

As with single pass bending, rotate adjusting nut to create end stop for repeatable bends.

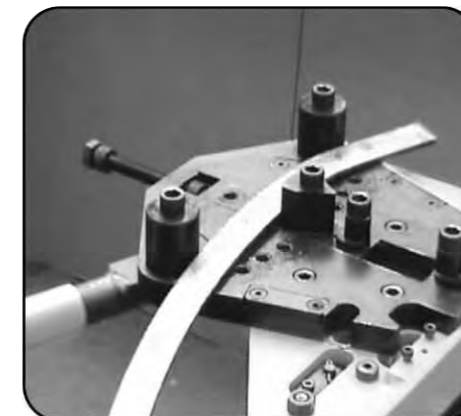

By repeating the process for a number of passes it is possible to build up a tighter curve on the bar gradually.

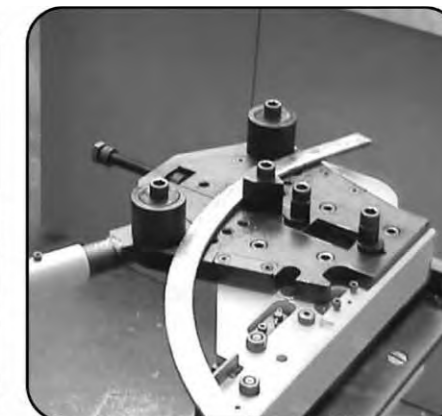

Even tighter curves can be achieved by use of the 'shims' on the 2 pillars again.

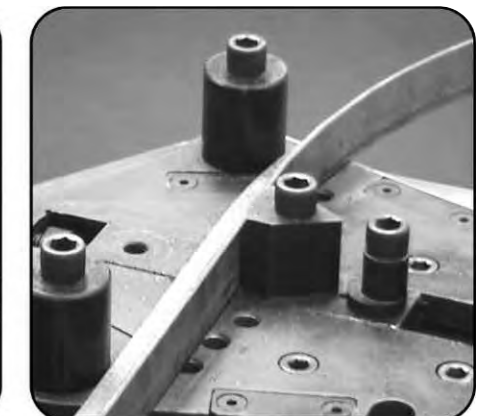

It is also possible to 'progressively bend' angle bar - in this case 30 x 30 x 3mm.



The key to achieving nice smooth curves is to bend gradually and consistently.

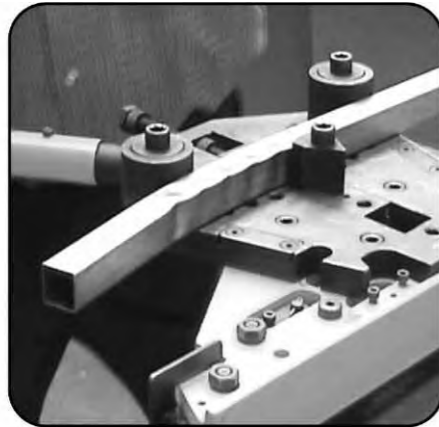

Square tube can also be bent - here 25mm square is progressively bent. Note the ripple in the tube that is created

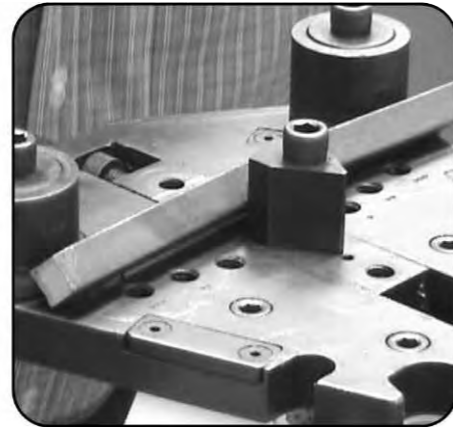

It is also possible to 'progressively bend' square bar on edge - up to 16mm square.

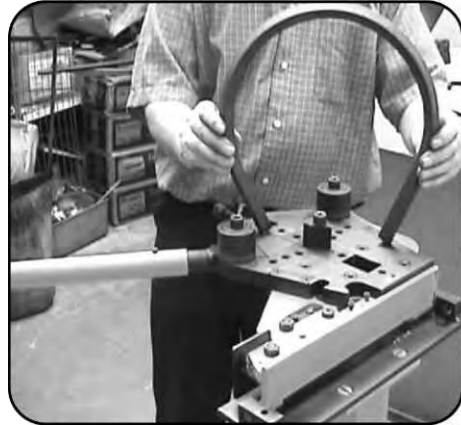

Tight curves can be achieved by a number of passes through the machine.



Channel or 'T' bar can also be curved using this process - this would be difficult to achieve by any other method.

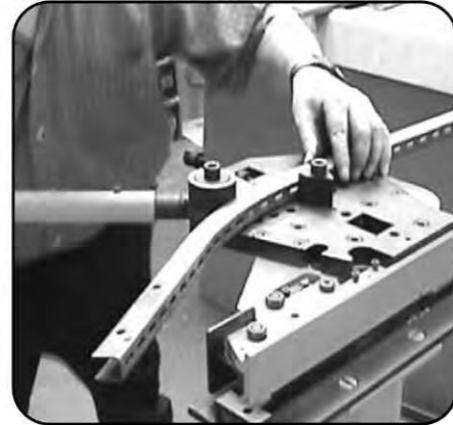

**metalcraft™**  
**XL 5+**  
**POWER BENDER**  
**OPTIONAL EXTRAS**

---

Pack 1 - Pedestal Mounting Kit

---

Pack 2 - Embossing & End Forging Kit

---

Pack 3 - Edge Bending Kit

---

Pack 4 - Tube Rolling Kit

---

Pack 5 - Microbending Kit