



## **OPERATOR'S HANDBOOK**

# **WM 18**



### **Warren Machine Tools Ltd**

**Warco House, Fisher Lane, Chiddingfold, Surrey GU84TD**

**Tel: 01428 682929**

**Fax: 01428 685870**

**E-mail: [warco@warco.co.uk](mailto:warco@warco.co.uk)**

**Web: [www.warco.co.uk](http://www.warco.co.uk)**

## NOTE

The information contained in this handbook is intended as a guide to the operation of these machines and does not form part of any contract. The data it contains has been obtained from the machine manufacturer and from other sources. Whilst every effort has been made to ensure the accuracy of these transcriptions it would be impracticable to verify each and every item. Furthermore, development of the machine may mean that the equipment supplied may differ in detail from the descriptions herein. The responsibility therefore lies with the user to satisfy himself that the equipment or process described is suitable for the purpose intended.

## A. LIMITED WARRANTY

Warren Machine Tools Ltd. Makes every effort to assure that its products meet high quality and durability standards and warrants to the original retail consumer/purchaser of our products that each product be free from defects in materials and workmanship as follow: 1 YEAR LIMITED WARRANTY ON ALL PRODUCTS UNLESS SPECIFIED OTHERWISE. This Warranty does not apply to defects due directly or indirectly to misuse, abuse, negligence or accidents, normal wear-and tear, repair or alterations outside our facilities, or to a lack of maintenance.

We shall in no event be liable for death, injuries to persons or property or for incidental, contingent, special, or consequential damages arising from the use of our products.

To take advantage of this warranty, the product or part must be returned to us for examination, postage prepaid. Proof of purchase date and an explanation of the complaint must accompany the merchandise. If our inspection discloses a defect, we will either repair or replace the product, or refund the purchases price if we cannot readily and quickly provide a repair or replacement, if you are willing to accept a refund. We will return repaired product or replacement at WARCO'S expense, but if it is determined there in no defect, or that the defect resulted from causes not within the scope of WARCO'S warranty, then the user must bear the cost of storing and returning the product.

The manufacturers reserve the right to change specifications at any time as they continually strive to achieve better quality equipment.

**Copyright.** The copyright of this instruction book is the property of Warren Machine Tools (Guildford) Ltd and may not be reproduced or copied without prior consent of Warren Machine Tools (Guildford) Ltd.

**WARNING!**

**Read and understand the entire instruction manual before attempting set-up or operation of this mill/drill**

- 1. This machine is designed and intended for use by properly trained and experienced personnel only.** If you are not familiar with the proper safe use of mill/drills, do not use this machine until proper Training and knowledge has been obtained.
- 2. Keep guards in place.** Safety guards must be kept in place and in working order.
- 3. Remover adjusting keys and wrenches.** Before turning on machine, check to see that any adjusting wrenches are removed from the tool.
- 4. Reduce the risk of unintentional starting.** Make sure switch is in the OFF position before plugging in the tool.
- 5. Do not force tools.** Always use a tool at the rate for which it was designed.
- 6. Use the right tool.** Do not force a tool or attachment do a job for which it was not designed.
- 7. Maintain tools with care.** Keep tools sharp and clean for best and safest performance. Follow instructions for lubrication and changing accessories.
- 8. Always disconnect the tools from the power Source before adjusting or servicing.**
- 9. Check for damaged parts.** Check for alignment of moving parts, breakage of parts, mounting, and any Other condition that may affect the tools operation.
- 10. Turn power off. Never leave a tool unattended.** Do not leave a tool until it comes to a complete stop.
- 11. Keep work area clean.** Cluttered areas and bench Invite accidents.
- 12. Do not use in a dangerous environment.** Do not Use power tools in damp or wet locations, or expose Them to rain. Keep work area well lighted.
- 13. Keep children and visitors away.** All visitors should be kept a safe distance from the work area
- 14 Make the workshop child proof.** Use padlocks, . master switches and remove starter keys.
- 15. Wear proper apparel.** Loose clothing, gloves, neckties, rings, bracelets, or other jewelry may get caught in moving parts. Non-slip footwear is recommended. Wear protective hair covering to contain long hair. Do not wear any glove.
- 16. Always use safety glasses.** Also use face or dust mask if cutting operation is dusty. Everyday eyeglasses only have impact resistant lenses, they are not safety glasses. accessories may be hazardous.
- 17 Do not overreach.** Keep proper footing and balance at all times.
- 18. Do not place hands near the cutterhead** while the machine is operating.
- 19. Do not perform any set-up work while machine is operating.**
- 20. Read and understand all warnings posted on the machine.**
- 21 This manual is intended to familiarize you with the technical aspects of this mill/drill.** It is not, nor was it intended to be, a training manual.
- 22. Failure to comply with all of theses warnings may result in serious injury.**
- 23. Some dust created** by power sanding, sawing, grinding, drilling and other construction activites contains chemicals known to cause cancer, birth defects or other reproductive harm.
- 24. Your risk from those exposures** varies, depending on how often you do this type of work. To reduce your exposure to these chemicals, work in a well ventilated are, and work with approved safety equipment

## MAIN TECHNICAL SPECIFICATION

### Specifications:

**WM-18**

Drilling Capacity .....	32mm
End Mill Capacity .....	20mm
Face Mill Capacity .....	76mm
Spindle Taper .....	MT3
Spindle Stroke .....	70mm
Head Tilt .....	±90°
Number of Spindle Speeds .....	Variable
Ranger of Spindle Speeds .....	50~2250 rpm
Working Surface of Table .....	840x210 mm
Max. Table longitudinal Travel .....	425mm
Max. Table Cross Travel .....	220mm
Max. vertical travel .....	370mm
Number of T-Slots .....	3
T-Slot Size .....	12mm
Motor .....	1.1KW, 1Ph, 230V
Overall Dimensions .....	710 x 890 x 1120mm
Net Weight(approx.) .....	220KGS
Shipping Weight (approx.) .....	260KGS

The specifications in this manual are given as general information and are not binding. Warco reserves the right to effect, at any time and without prior notice, changes or alterations to parts, fitting and accessory equipment deemed necessary for any reason whatsoever.

## TABLE OF CONTENTS

WARRANTY .....	1
WARNINGS .....	2
SPECIFICATIONS .....	3
TABLE OF CONTENTS .....	4
CONTENTS OF SHIPPING CONTAINER .....	5
UNPACKING AND CLEAN-UP .....	5
ASSEMBLY.....	6
INSTALLATION .....	6
CONTROLS.....	7 - 8
ELECTRICAL CONNECTIONS.....	9
ARBOR REPLACE .....	10
GIB ADJUSTMENT.....	11
MAINTENANCE.....	12
TROUBLE SOLUTION.....	12

**⚠ WARNING!**

**Read and understand the entire contents of this Manual before attempting set-up or operation!  
Failure to comply may cause serious injure!**

## **CONTENTS OF SHIPPING CONTAINER**

- 1 Mill/Drill Machine
- 1 Drawbar
- 1 Digital Scale
- 1 Test Flow Chat
- 1 Operator manual
- 1 Toolbox & Tools

### **Toolbox Contents (Fig. 01)**

- 1 Oil Gun
- 1 MT3 Arbor
- 2 Double End Spanner (17-19, 22-24mm)
- 6 Hex Socket Wrench (2.5,3,4,5,6,8mm)
- 1 Flat Blade Screwdriver
- 1 Cross Blade Screwdriver
- 4 Handle
- 2 M12 "T" Screw
- 2 M10 Washer
- 2 M10 Nut



**Fig. 01**

### **Unpacking and Clean-up**

- 1. Finish removing the wooden crate from around the mill/drill.
- 2. Unbolt the machine from the crate bottom.
- 3. Sling mill/drill with the proper equipment.
- 4. Clean all rust protected surfaces using a mild commercial solvent, kerosene or diesel fuel. Do not use paint thinner, gasoline, or lacquer thinner. These will damage painted surfaces. Cover all cleaned surfaces with a light film of machine oil.

## Assembly

1. Screw handles (A, Fig.02) onto handwheel (B, Fig.3) and tighten.
2. Repeat for remaining handles of table.

## Installation



### WARNING!

Machine is heavy! Use an appropriate lifting device and use extreme caution when moving the machine to its final location. Failure to comply may cause serious injury!

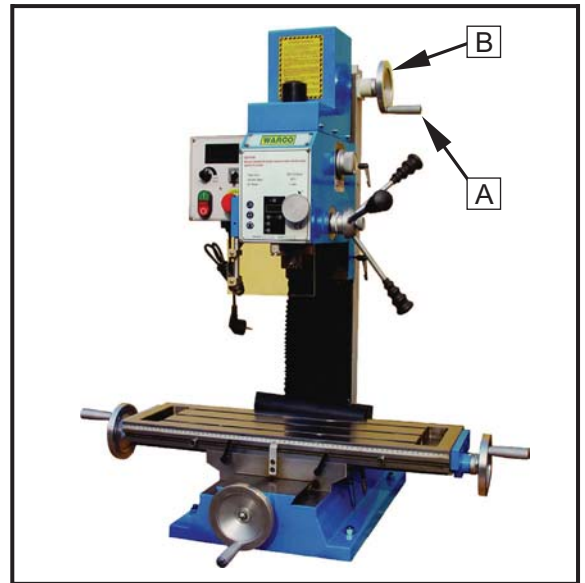

Fig. 02

1. The location for the mill/drill should be well lit, dry, and have room enough to allow the head to rotate 360°.
2. Carefully lift the mill/drill with properly rated equipment to a sturdy stand or working bench. For best performance, through bolt the mill/drill to a stand.  
**We do not recommend that unattached machines be operated, as the machine will move during operation!**
3. Before bolting the mill/drill to a bench or stand, the unit must be level in both directions. Place a level on the table in both directions.
4. If the table of mill is not to level, shim under the low corner(s) until level. Tighten the fastening bolts. Check for level again. Adjust as necessary until the mill/drill is level. Check again when securing bolts are tightened.

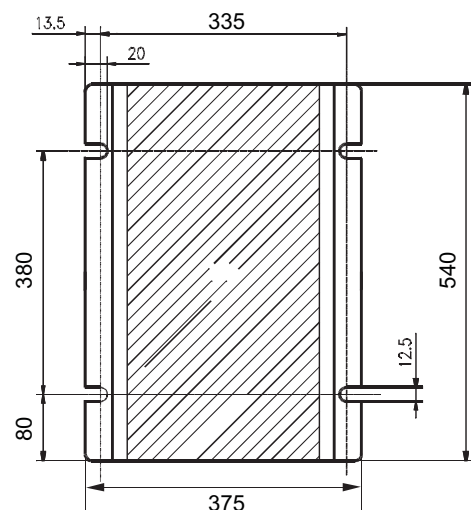
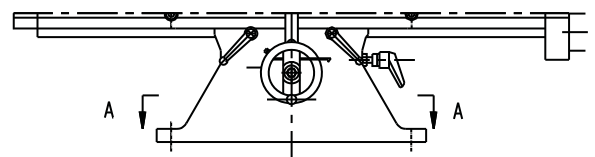

Fig. 03

## Installation Drawing (Fig. 03)

The installation drawing described below may differ from the real dimensions. The tolerances are in the range of the general tolerances according to DIN 7168.

## Controls

### Longitudinal Handwheel (A, Fig. 04)

Located on two side of the table. Moves table side to side.

### Cross Feed Handwheel (B, Fig. 04)

Located on the front of the base. Moves table toward, or away from the column.

### Head Elevating handwheel (C, Fig.05),

Locate on the right of column. The head can be adjusted up or down to suit height requirements for different workpieces. Turn it clockwise to up head on the column and counter-clockwise to down. **When the head is at the desired height, lock in place with the locks.**

**Caution: Have to loosen the locks for the slideways before above operation!**

### Adjustable Table Stops (D, Fig.06)

Located on table front. Adjust to stop table at any setting along the longitudinal axis.

### Table locks

Longitudinal table locks (E, Fig. 06) are located on front of the table. Cross-feed table locks (F, Fig.05) are located on the right side under the table. Turn clockwise to lock the slideways.

### Mill Head locks (G, Fig.07)

Located on the right of column. Turn clockwise to lock the mill head.

### Quill Lock Lever (H, Fig. 07)

Located on the left of the mill head. The height of the spindle can be locked with the quill lock lever. Set the desired height with the quill lever and turn the lever down. Turn clockwise to lock the quill, reverse to loosen.

**Caution: For best results. All milling operations should be done with the quill/spindle as close to the head assembly as possible. Lock spindle, table and mill head in place before starting milling operations!**

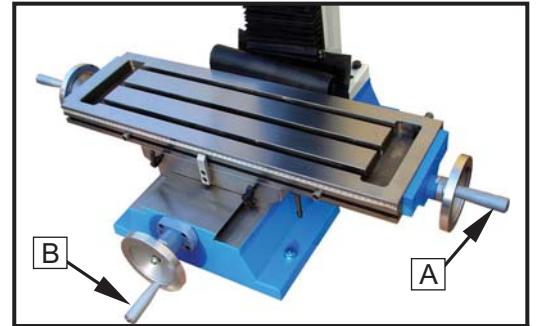

Fig. 04



Fig. 05

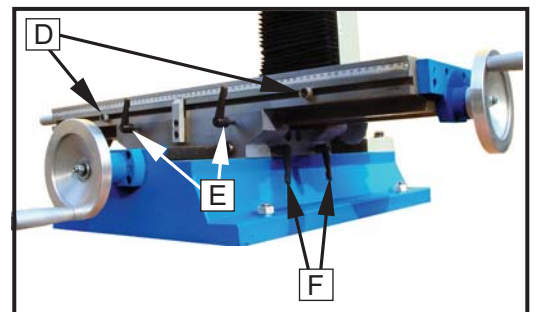

Fig. 06



Fig. 07



**Down feed Handles: (J, Fig. 08):**

Located on the right side of the head casting. Counter-clockwise movement advances the quill toward the table. Return spring retracts the handles. **The knob (K, Fig. 08) must be loose before the operating the handles.** The graduated dials (L, Fig. 08) on the handle base can be indexed or “zeroed” to help make accurate and convenient movements.

**Fine Down Feed**

Turn counter-clockwise the knob (K, Fig. 08) to engage the fine down feed knob (M, Fig. 08) what located on the front of the head. Turn it according to you want to move downward, Clockwise turn the hand wheel to down feed the spindle, reverse to retract it.

**Mill Head Rotation**

The head is designed to tilt 90• either left or right, enabling it to perform task such as angle drilling or horizontal slotting. Loosen the lock nuts (N, Fig. 09) under the head. Rotate the head to its desired position, using the reference guide (O, Fig.09). Once in place, re-tighten the lock nuts.

**Note: make sure to provide support for the head so it doesn’t unexpectedly rotate on its own. Always maintain control of the head.**

Keep in mind that the head must be dialed in when it’s returned to the “zero” position if high levels of accuracy are required. If you are able to use an angle vise to accomplish your milling operation without tilting the mill head, you will save yourself a good amount of set-up time.

**High/Low Speed Knob (P, Fig. 10)**

Located on the right of the mill head. You can select H/L speed by moving the knob right or left. **Note: Change speed keep machine is at low speed!** See the chart below for spindle speeds:

SPINDLE SPEED  $\text{r}/\text{min}$

L	H
50-750	150-2250

**Caution: Even at low spindle speeds, metal fragments from the cutting process can be expelled by the mill/drill. Always wear eyewear and protective clothing when operating the machine!**

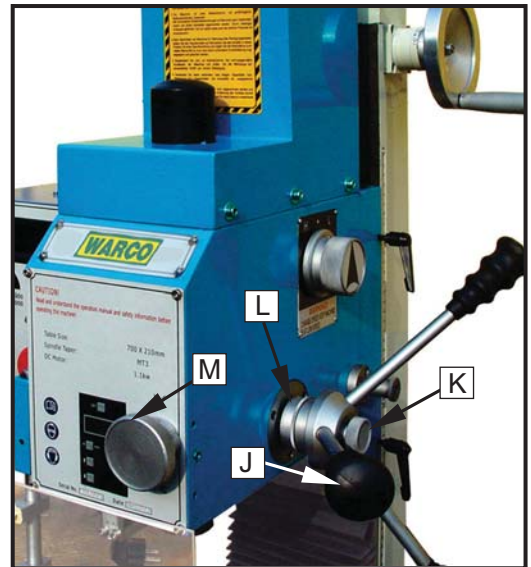

Fig. 08

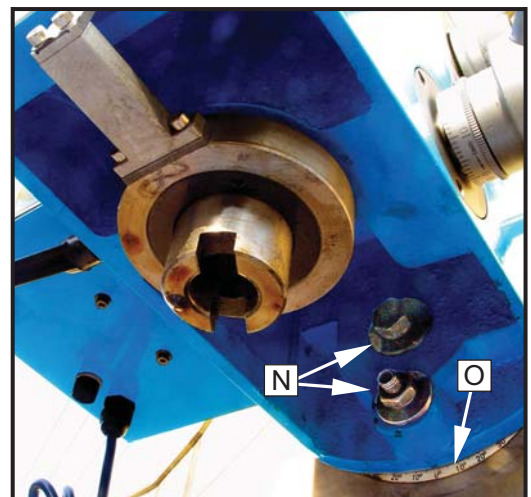

Fig. 09

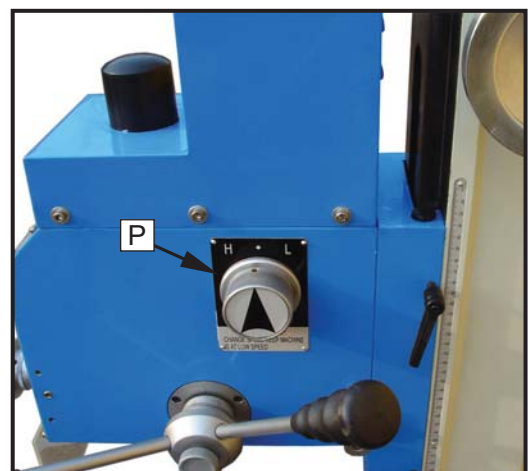

Fig. 10

## Electrical Connections



### WARNING!

A qualified electrician must make all electrical connections!

Failure to do so may cause serious injury!

Before connecting the machine to the mains, make sure that the electrical values of the mains supply are the same as those for the machine's electrical components. Use the wiring diagram (Fig. 11) for connecting the lathe to the mains supply.



### WARNING!

Make sure the machine is properly ground!

Failure to do so may cause serious injury and damage to user!

**DC-Motor** - its type is 108ZYT, 230v, 5000rpm, 5.2A, 1.100W

**Make sure that all 2 phase (L, N) are connected.**

Defective or incorrect connection will render the guarantee null and void.

Indicators are:

Motor runs hot immediately (3-4 minutes).

Motor doesn't run silently and has no power.

**Emergency Stop Switch** (A, Fig.12) function of emergency stopping and the protective function to the machine and electric components. (B, Fig.12) Green push button marked "I" to start the motor, Red push button marked "O" to switch the motor off.

**Speed Control Knob** (C, Fig. 12) turn it clockwise to increase the spindle speed, reverse to decrease. The knob should be turned to zero each time the machine is stopped. Always start the machine with the knob set at zero.

**F/R switch** (D, Fig.12) changing the position of switch will reverse the direction of the motor. F-forward direction, R- reverse direction.

**Fuse Base** (E, Fig. 13) located on the back plate of electrical box. Fuse what rate is 12 A is put in the base. Turn counter-clockwise the button to open and change the fuse, reverse to retighten.

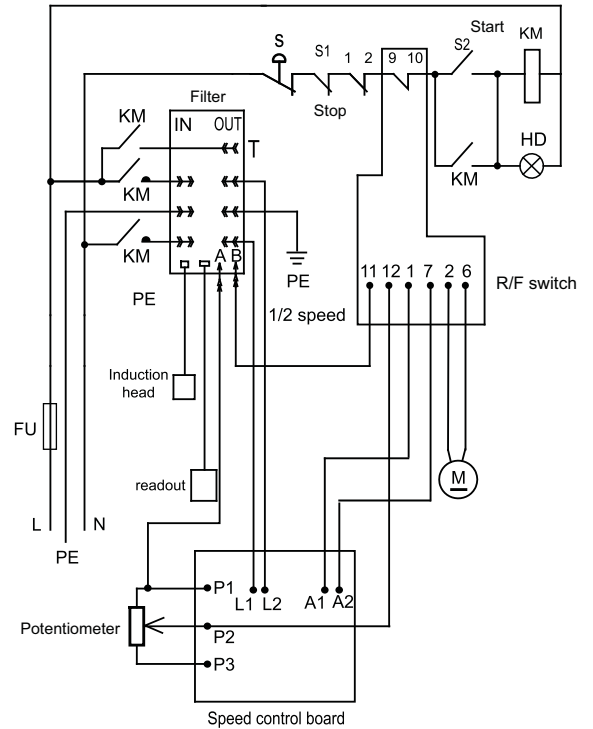

Fig.11



Fig.12

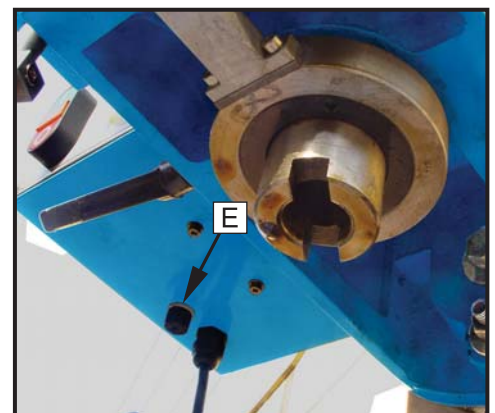

Fig.13

**⚠ WARNING!**

This machine is designed and intended for use by properly trained and experienced personnel only! If you are not familiar with the proper and safe use of mill/drills, don't use the machine until proper training and knowledge have been obtained! Failure to comply may cause serious injury!

### Arbor Replacement

1. Disconnect machine from the power source, unplug.
2. Remove the cover of drawbar onto the motor cover (A, Fig. 14).
3. Hold the flat of spindle (B, Fig. 15) to keep it from moving while loosening the drawbar (C, Fig. 16) with the 22-25 spanner in toolbox.
4. Loosen the drawbar approximately three to four full turns.
5. Tap the drawbar head with a rubber mallet to dislodge the arbor.
6. Grasp the arbor with one hand while loosening the drawbar with the other. Continue to loosen the drawbar until the arbor can be withdrawn from the spindle. Wipe out the spindle with a clean dry rag.
7. Wipe down the new arbor with a clean dry rag and place the arbor into the spindle. Thread the drawbar into the arbor. Tighten the drawbar with a spanner while holding the spindle.

**⚠ WARNING!**

Do not loosen the drawbar more than three or four turns before hitting with a rubber mallet. Damage to the drawbar threads may occur!

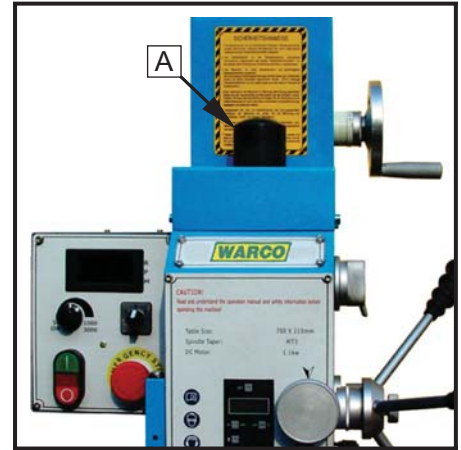

Fig. 14

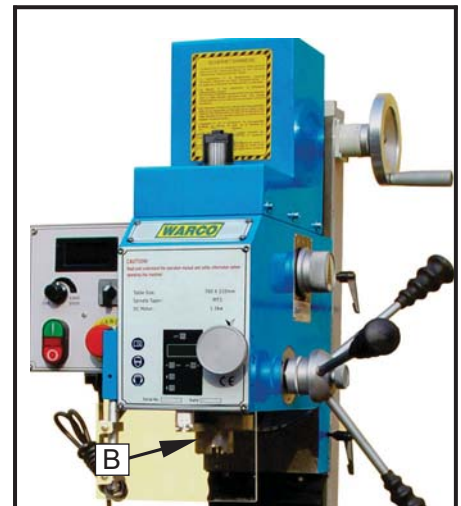

Fig. 15



Fig. 16

## Gibs Adjustment

After a period of time, movement of the table over the ways will cause normal wear. Adjust the gibs to compensate for this wear.

1. The horizontal gib adjustment screw (A, Fig.17) is found to the rear right on table. The traverse gib adjustment screw (B, Fig.17) is found on the right side of saddle under the table. The vertical gib adjustment screw (C, Fig.18) is found onto the column.
2. Loosen the screw from small taper end of gib. Turn the screw from large taper end of gib slightly clockwise to tighten. Turn the table handwheel and check the tension.
3. Re-adjust as required.

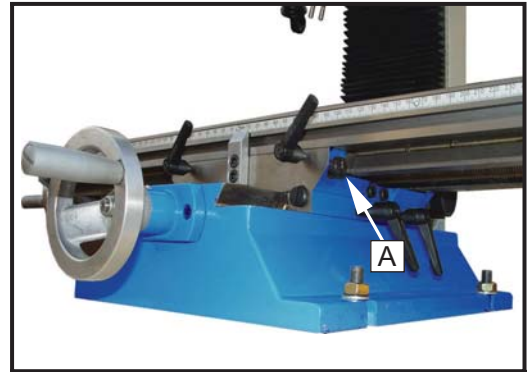

Fig. 17

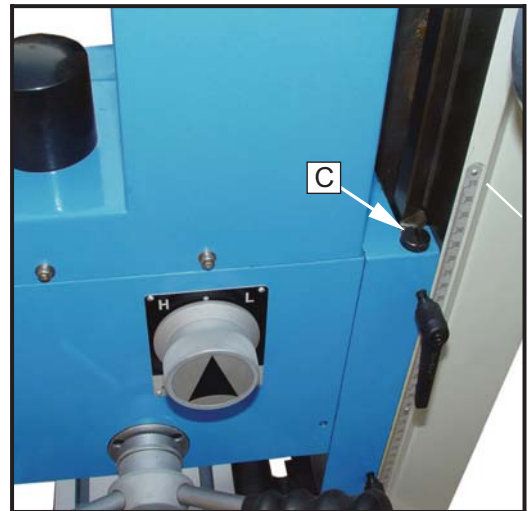

Fig. 18



## Maintenance

Keep the maintenance of the machine tool during the operation to guarantee the accuracy and service life of the machine.

1. In order to retain the machine's precision and functionality, it is essential to treat it with care, keep it clean and grease and lubricate it regularly. Only through good care, you can be sure that the working quality of the machine will remain constant. **Disconnect the machine plug from the mains supply whenever you carry out cleaning, maintenance or repair work!**
2. Lubrication all slideways lightly before every use. The leadscrew must also be lightly lubricated with lithium base grease.
3. During the operation, the chips what falls onto the sliding surface should be cleaned timely, and the inspection should be often made to prevent chips falling into sliding ways. Asphalt felt should be cleaned at certain time. **Do not remove the chips with your bare hands. There is a risk of cuts due to sharp-edged chips.**
4. After the operation every day, eliminate all the chips and clean different part of the machine and apply machine oil to prevent rusting.
5. In order to maintain the machining accuracy, take care of the arbor, drawbar, the surface of the worktable and the guide way and avoid mechanical damage and the wear due to improper guide.
6. If the damage is found, the maintenance should be done immediately.

## Trouble Solution

Problem	Possible Cause	Solution
Too chatters	Gibs too loose on table, column Unused feeds not locked Mill head not locked Quill too loose Tool not on center Improper tool shape, tool dull	Readjust gibs Lock all axes but the one moving Lock mill head Tighten quill lock Center tool reshape, sharpen, or replace tool
Depth of cut is not consistent	Quill moving Setup wrong	Lock quill Make sure setup is parallel to table
Hole is off center or bit wanders	Bit dull Bit not mounted correctly in chuck Chuck loose in spindle Drawbar not secured Bearing loosen or worn Cutting too fast	Use sharp bits Remount tool Remount chuck on arbor Tighten drawbar Tighten or replace bearings Reduce speed
Bit turns erratically or stops	Bit fed into work too fast	Reduce feed rate
Chuck is difficult to tighten or loosen	Chuck sticking Debris in chuck	Apply lubricant Clean chuck
Chuck wobbles	Chuck loose on arbor Drawbar not tight	Clean arbor and remount Clean spindle and replace drawbar
Turn on machine and nothing happen	Machine unplugged Loose electrical connections	Plug in machine Tighten wiring connections



**PARTS LIST for**  
**WM 18**

**Warren Machine Tools Ltd**

**Warco House, Fisher Lane, Chiddingfold, Surrey GU84TD**

**Tel: 01428 682929 Fax: 01428 685870**

**E-mail: [warco@warco.co.uk](mailto:warco@warco.co.uk)**

**Web: [www.warco.co.uk](http://www.warco.co.uk)**

# WM18- MILLING & DRILLING MACHINE

## Mill Head Assembly

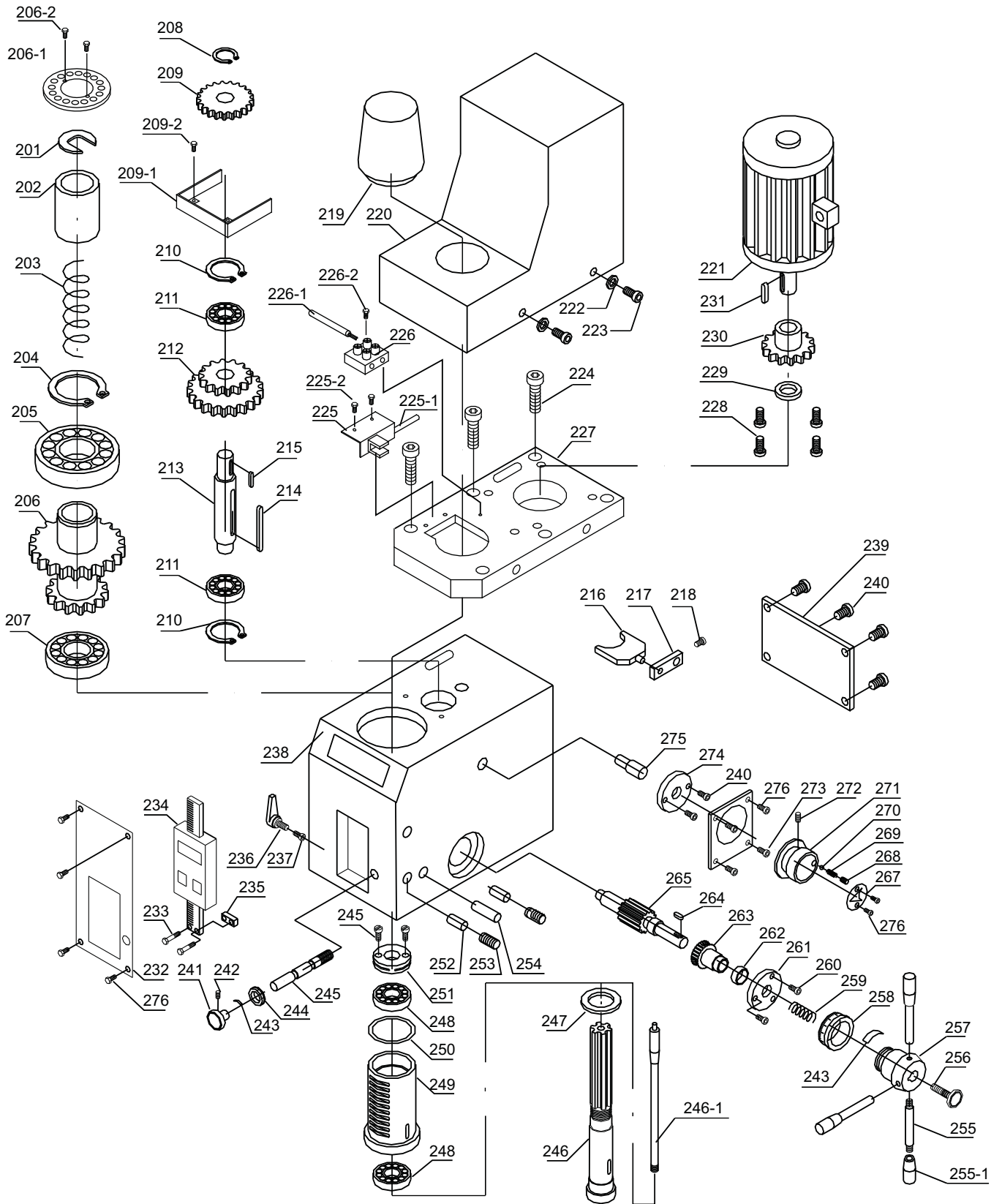

## WM18 MILL HEAD ASSEMBLY I

No.	Parts No.	Description	Specification	Qty
1	201	Position Washer		1
2	202	Bush		1
3	203	Spring	2.5x28x100	1
4	204	Snap Ring	Φ 45	1
5	205	Bearing	6209	1
6	206	Gears	60/70T	1
7	206-1	Raster Ring	16 Bore	1
8	206-2	Screw	M3x8	2
9	207	Bearing	7007	1
10	208	Snap Ring	Φ 15	1
11	209	Gears	37T	1
12	209-1	Guard		1
13	209-2	Screw	M3x6	2
14	210	Snap Ring	Φ 32	2
15	211	Bearing	6002	2
16	212	Shafting Gear	42/62T	1
17	213	Shaft		1
18	214	Key	5X50	1
19	215	Key	C5x12	1
20	216	Fork		1
21	217	Fork Arm		1
22	218	Set Screw	5x8	1
23	219	Drawbar Cover		1
24	220	Motor Cover		1
25	221	Motor	91ZYT005	1
26	222	Washer	M4x8	6
27	223	Washer	M4	6
28	224	Screw	M6x14	6
29	225	Bracket for finder		1
30	225-1	Electrical wire		1
31	225-2	Screw	M3x6	2
32	226	Terminal		1
33	226-1	Electrical wire		1
34	226-2	Screw	M3x12	1
35	227	Motor Plate		1
36	228	Screw	M5x12	6
37	229	Snap Ring	M10	1
38	230	Gear	25T	1
39	231	Key	C4X6	1
40	232	Label		1
41	233	Screw	M3x6	2
42	234	Digital Scale		1



## WM 18 MILL HEAD ASSEMBLY II

No.	Parts No.	Description	Specification	Qty
43	235	Base		1
44	236	Locking Lever	M8x20	1
45	237	Brass Pin		1
46	238	Mill Head		1
47	239	Plate for Head		1
48	240	Screw	M4x8	6
49	241	Knob		1
50	242	Set Screw	M5x6	1
51	243	Spring Piece		2
52	244	Dial		1
53	245	Worm Shaft		1
54	246	Spindle		1
55	246-1	Drawbar		1
56	247	Ring		1
57	248	Bearing		2
58	249	Sleeve		1
59	250	Rubber Ring	58x2.65	1
60	251	Adjusted Nut		1
61	252	Brass Pin	B4x20	4
62	253	Set Screw	M5X12	4
63	254	Pin	A6x30	1
64	255	Handle		3
65	256	Knob		1
66	257	Base		1
67	258	Dial		1
68	259	Spring	1.2x12x2.5	1
69	260	Screw	M4X40	3
70	261	Flange		1
71	262	Washer		1
72	263	Worm Gear		1
73	264	Key	4x12	1
74	265	Gear Shaft		1
75	266	Flange		1
76	266-1	Screw	4x12	3
77	267	H/L Speed Indication Label		1
78	268	Set Screw	M8x8	1
79	269	Spring	0.8x5x25	1
80	270	Ball	Φ 6.5	1
81	271	Knob		1
82	272	Set Screw	M5x16	1
83	273	H/L Speed Label		1
84	274	Flange		1
85	275	Fork Shaft		1

# WM18- MILLING & DRILLING MACHINE

## Column, Table, Base Assembly

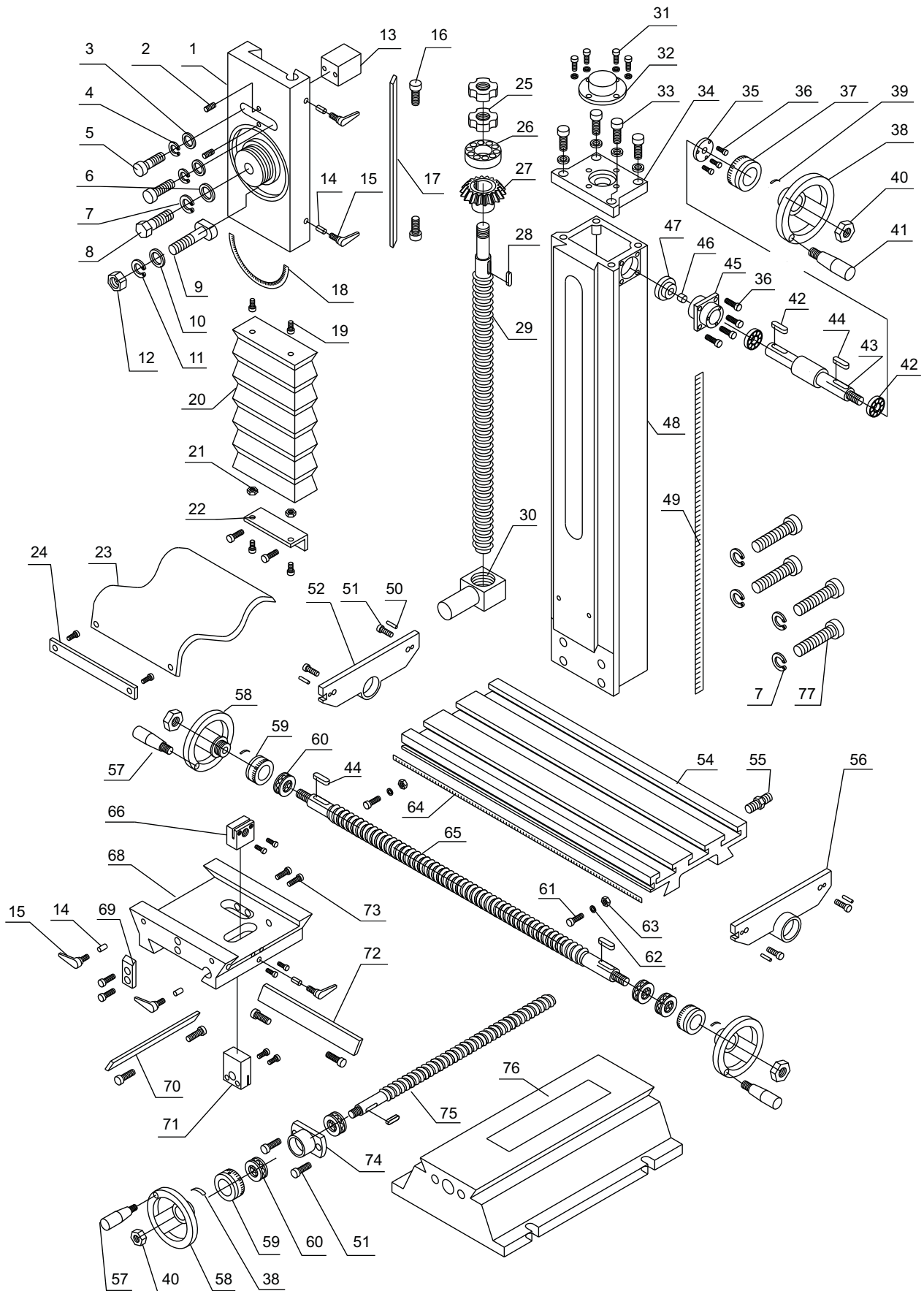

**WM18 COLUMN, TABLE, BASE ASSEMBLY I**

	<b>Parts No</b>	<b>Description</b>	<b>Specification</b>	<b>Qty</b>
86	1	Vertical Slide		1
87	2	Screw	M6x16	2
88	3	Washer		2
89	4	Spring Washer	8	6
90	5	Screw	M8x25	2
91	6	Screw	M12x40	1
92	7	Spring Washer	12	5
93	8	T-Nut	12	1
94	9	Bolt		1
95	10	Washer	M10	1
96	11	Spring Washer	M10	1
97	12	Nut	M10	1
98	13	Block		1
99	14	Brass Pin		5
100	15	Locking Lever	M6x16	5
101	16	Gib Screw		1
102	17	Gib		1
103	18	Angie Indication Label		1
104	19	Screw	M5x10	12
105	20	Dust Cover		1
106	21	Nut	M5	2
107	22	Connect Rib		1
108	23	Dust Cover		1
109	24	Connect Rib		1
110	25	Nut	M16x1.5	2
111	26	Bearing		1
112	27	Gear		1
113	28	Key	4x16	2
114	29	Vertical Leadscrew		1
115	30	Nut		1
116	31	Washer	M5	4
117	32	Cover		1
118	33	Screw	M8x20	4
119	34	Bracket		1
120	35	Flange		1
121	36	Screw	M5x12	7
122	37	Dial		1
123	38	Spring Piece		4
124	39	Handwheel		1
125	40	Locking Nut		4
126	41	Handle	M10x80	1

WM18 COLUMN, TABLE, BASE ASSEMBLY II

No.	Parts No.	Description	Specification	Qty
127	42	Bearing	6001	2
128	43	Shaft		1
129	44	Key	4x12	2
130	45	Bearing Housing		1
131	46	Bush		1
132	47	Gear		1
133	48	Column		1
134	49	Label	A5x25	1
135	50	Pin	M6x16	10
136	51	Screw		1
137	52	Left Bracket		1
138	54	Working Table		1
139	55	Plug		1
140	56	Right Bracket		1
141	57	Handle	M8x63	3
142	58	Handwheel		3
143	59	Dial		3
144	60	Bearing		5
145	61	Screw	M6x10	2
146	62	Bush		2
147	63	T-Nut		1
148	64	Scale		1
149	65	Longitudinal Leadscrew		1
150	66	Longitudinal Nut		1
151	67	Adjusted Screw	M4x20	4
152	68	Cross Slide		1
153	69	Position Block		1
154	70	Cross Gib		1
155	71	Cross Nut		1
156	72	Longitudinal Gib		1
157	73	Screw	M6x25	2
158	74	Bearing Housing		1
159	75	Cross Leadscrew		1
160	76	Base		1
161	77	Screw	M12x90	4

# WM18 MILL ELECTRICAL BOX ASSEMBLY

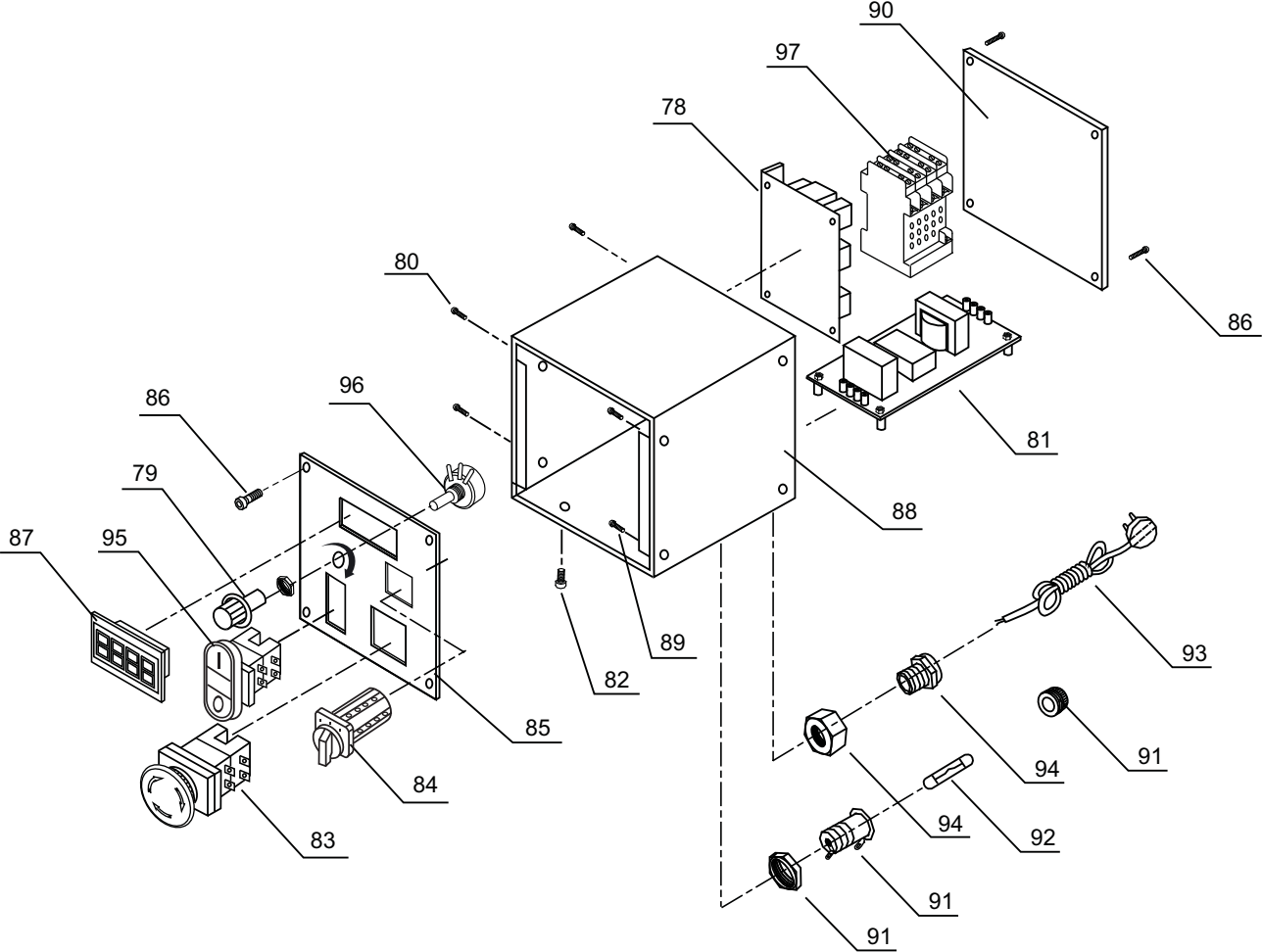

## WM18 MILL ELECTRICAL BOX ASSEMBLY

<b>No.</b>	<b>Parts No.</b>	<b>Description</b>	<b>Specification</b>	<b>Qty</b>
1	78	Speed Control		1
2	79	Timing Knob		1
3	80	Screw	M3x8	4
4	81	Filter		1
5	82	Screw	M3x16	4
6	83	Emergency Swich		1
7	84	R/F Swich		1
8	85	Electrical Plate		1
9	86	Screw	M4x6	8
10	87	Speed Display		1
11	88	Electrical Box		1
12	89	Screw	M5x8	4
13	90	Cover		1
14	91	Fuse Holder		1
15	92	Fuse (10A)		1
16	93	Plug		1
17	94	Strand Relief		1
18	95	ON/OFF Swich		1
19	96	Potentiometer		1
20	97	AC Contactor		1

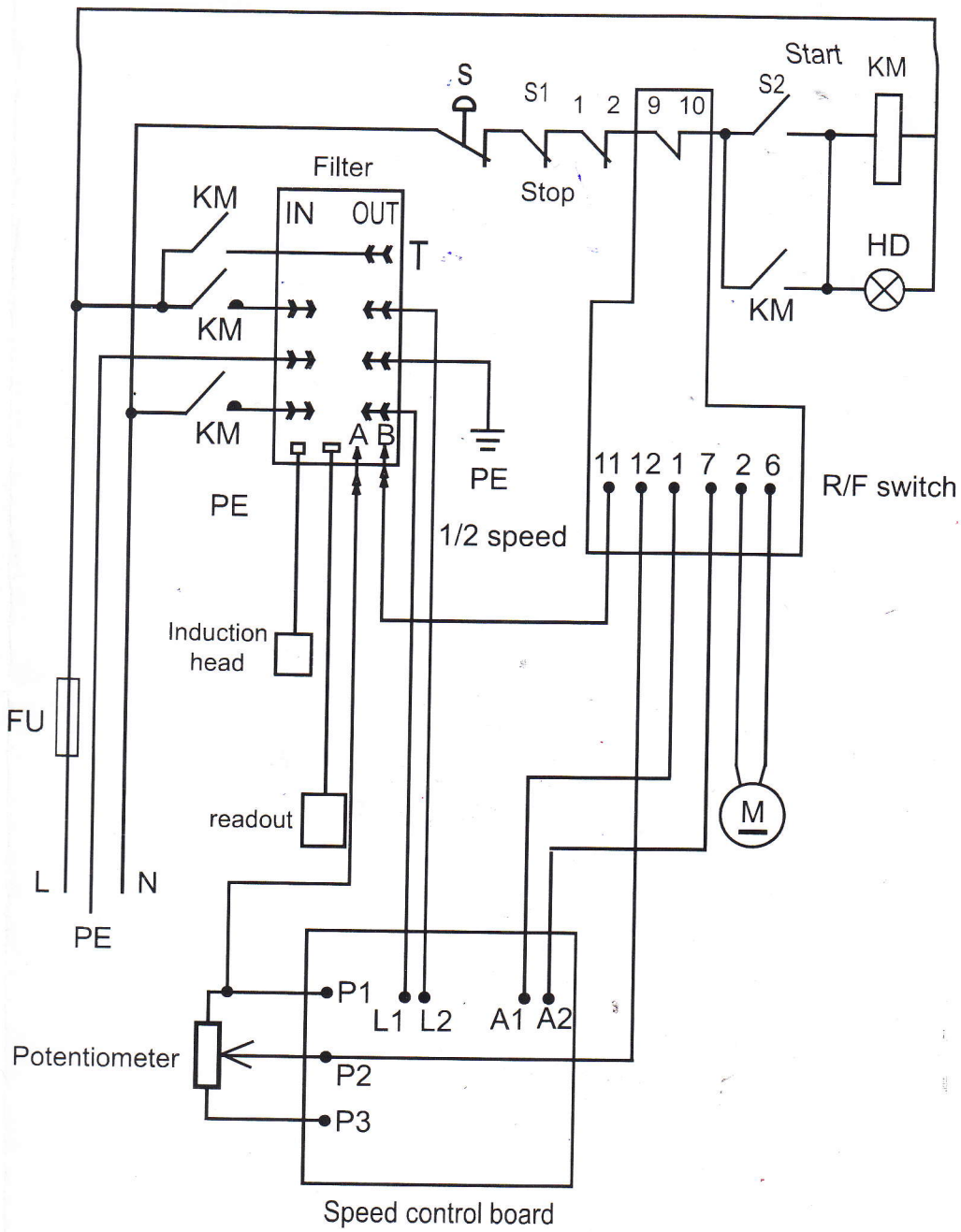

**Fig.11**



**WARCO**