

INSTRUCTION MANUAL
FOR
DRILLING AND MILLING MACHINE

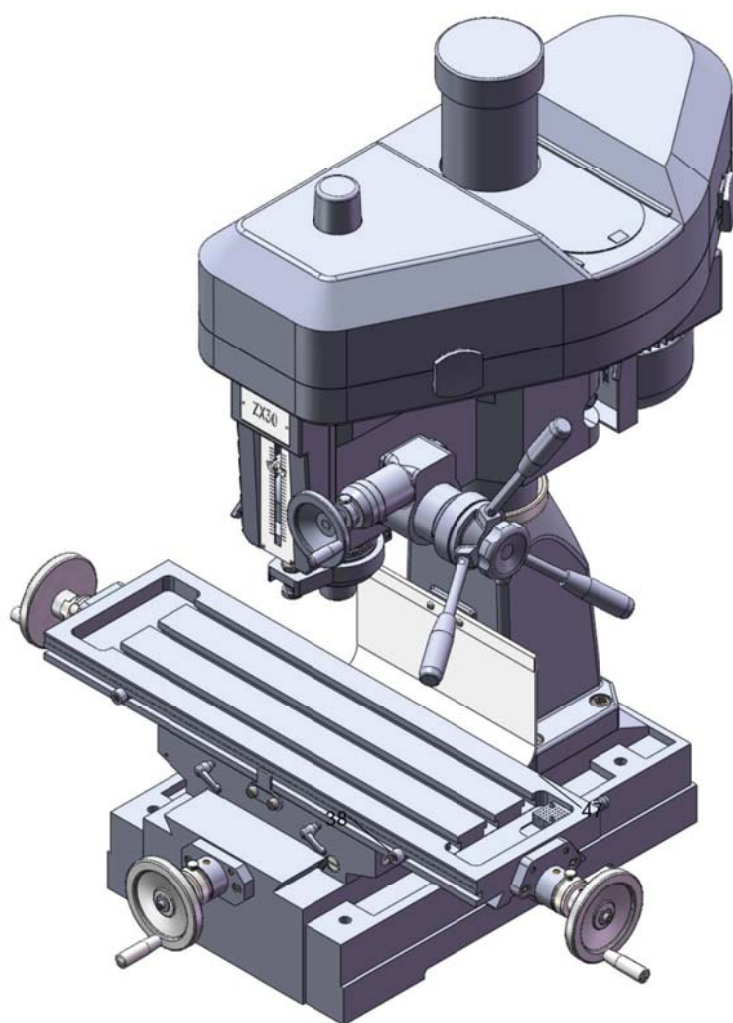

Thank you for purchasing the ZX30 Complex Machine. If properly cared for and operated, this machine can provide you with years of accurate service. Please read this manual carefully before using your machine.

1.SPECIFICATION

Model	30
Drilling capacity	32mm (1-1/4")
Face mill capacity	76mm (3")
END mill capacity	20mm 3/4")
Swing	395mm (15-1/2")
Max distance spindle nose to table	460mm (18")
Spindle taper	MT3 or R8
Spindle stroke	120mm (4-3/4")
Diameter of spindle sleeve	75mm (3")
Head swivel	360°
Diameter of column	115mm (4-1/2")
Overall height	1100mm (43-1/2")
Length	1080mm (42-1/2")
Width	1010mm (39-3/4")
Motor	1.5kw (2HP)
Spindle speed (12S)	50Hz 100~2080 (4 pole) 60Hz 120~2500 (4 pole)
Forward and backward travel of table	175mm(7")
Right and left travel of table	500mm(19-3/4")
Working area of table	730mm×210mm (28-3/4" ×8-1/4")
Gross weight	300kg
Measurement	1.2m3

2.FEATURES:

(1)This machine has several uses,such as surface cutting,drilling,milling,and also can be equipped with and electric switch for tapping.

(2)This machine is of fine quality,can be operated easily,and it is not limited to skilled operators.

(3)The drilling and milling operation can be performed by two methods.

1)Hand operation,which makes quick drilling.

2)Worm gear feed operation which makes slow milling.

3)Bronze adjustable nuts,which adjust the thread clearance and reduce the wear They also make screws rotated smoothly and increase the thread accuracy.

4)Whole column which makes this machine strong,stable,and also keep the high accuracy.

5)Head of tough cast ensures its accuracy lasting and enduring through the treatment of precise boring cylinder,grinding,and internal stress relief.

6)To adjust belt and change speed,new pulley cover is easy to open the cover.

3.MOUNTING MACHINE

(1)Be sure to fix the head on the column and put the hanger of the head before moving machine While moving machine,please keep its balance and safety.

(2)Do not mount machine at the sunshine place to avoid the deformity of machine and the loss of accuracy.

(3)Check to see if the motor turning in clockwise direction before connecting the electric distribution line.

(4)Mount machine to a sturdy table or base.It is advisable that the table you choose be well constructed to avoid any vibration during operation.

(5)Four holes are provided on the machine base for mounting .Before tightening bolts make sure the work table on the machine is level lengthwise and crosswise.Use shims if necessary.

4.CLEANING & LUBRICATING

(1)Your machine has been coated with a heavy grease to protect it in shipping.This coating should be completely removed before operating the machine.Commercial degreaser,kerosene or similar solvent may be used to remove the grease from the machine,but avoid getting solvent on belts or other rubber parts.

(2)After cleaning,coat all bright work with a light lubricant,Lubricant all points in Fig.1 with a medium consistency machine oil.

(3)Lubricating points as shown in arrows.

5.USE OF MAIN MACHINE PARTS (See Fig.1)

(1)To raise and lower the head by head handle.

(2)Equipped with an electric switch for tapping operation clockwise or counter clockwise.

(3)To adjust the quick of slow feeding by feed handle.

(4)To adjust the table left and right travel by table handle wheel.

(5)To adjust the table fore and aft travel by table handle wheel.

(6)To operate the spindle handle wheel for micro feed.

(7)To adjust the scale size according to working need.

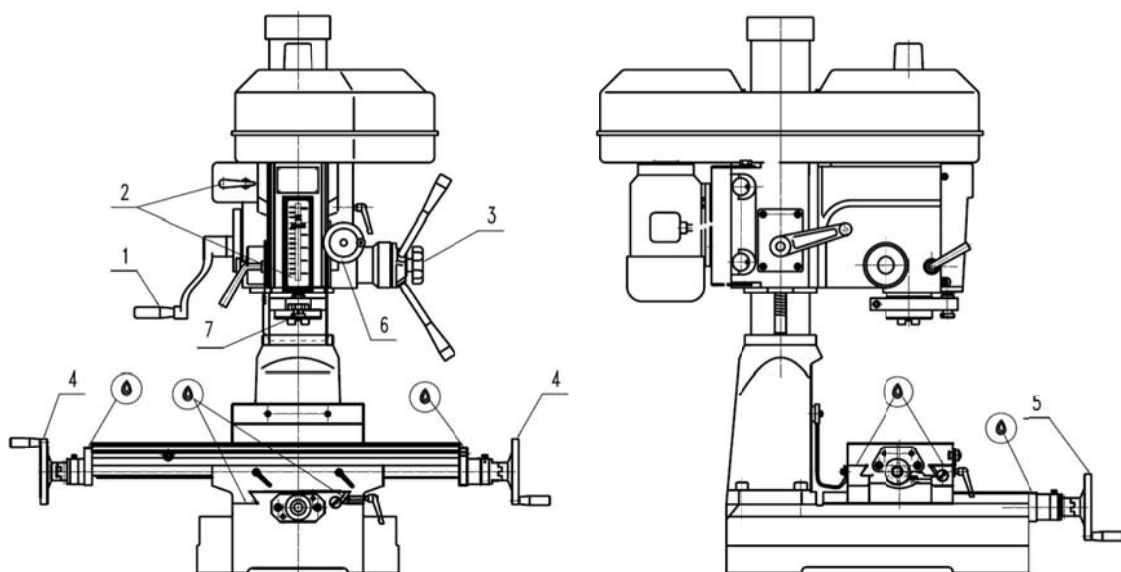

Fig.1

6.PRECAUTION FOR OPERATION

Check all parts for proper condition before operation,if normal safety precautions are notice carefully, this machine can provide you withstanding of accurate service.

(1)Before operation

(a)Fill the lubricant.

(b)In order to keep the accurate precision.The table must be free from dust and oil deposits.

(c)Check to see that the tools are correctly set and the workpiece set firmly.

(d)Be sure the speed is not set too fast.

(e)Be sure everything is ready before.

(2)After Operation

(a)Turn off the electric switch.

(b)Turn down the tools.

(c)Clean the machine and coat it with lubricant.

(d)Cover the machine with cloth to keep out the dust.

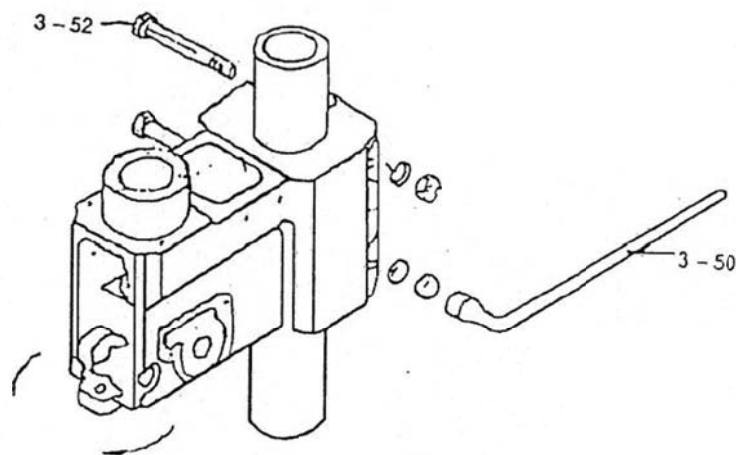

Fig.2

(3)Adjustment of head

(a)To raise and lower the head,loosen the two bolts(3-52)shown if Fig.2.Use

the left side head handle(3-50)to raise and lower the head on its rack and pinion mechanism.When the desired height is reached,tighten ten bolts to avoid vibration.

(b)Head may be rotated 360° by loosening the same bolts mentioned above.Adjust he head to the desired angle,the fix the bolt according to 3-52,Tighten three bolts and the sometime to fix the head if drilling & milling too much.

(4)Preparing ZX30 for drilling

(a)Make the feed handle and the worm inner gear unclenching by moving feed handle, the stop down feed.

(b)To loose adjustable lock make the tapper of worm gear and spring base will not close tight. Then adjust spindle to the proper place of working range.

(5)Preparing ZX30 for Milling

(a)Adjust screw on the graduated dial to its highest position.

(b)Make the feed handle and the worm inner gear clutching by moving the feed handle,then perform milling by micro feed.

(c)Adjust spindle to the desired working position by spindle handle wheel and lock the rack gear sleeve at the desired height with fixed bolt.

7.ADJUSTING TABLE SLACK

(1)Your ZX30 is equipped with full length tapered siding plate(4-07) to adjust for excess slack it fore and aft left and right table travel.

(2)Tighten the sliding plate bolt(4-12) clockwise with a big screw driver for excess slack.

(3)Release the sliding plate bolt a little counterclockwise if too tight.

(4)To adjust left and right travel,adjust the sliding plate bolt until feel a slight drag when turning the table(Fig.3)

(5)To adjust fore and aft travel,adjust the sliding plate bolt as shown in Fig.3.

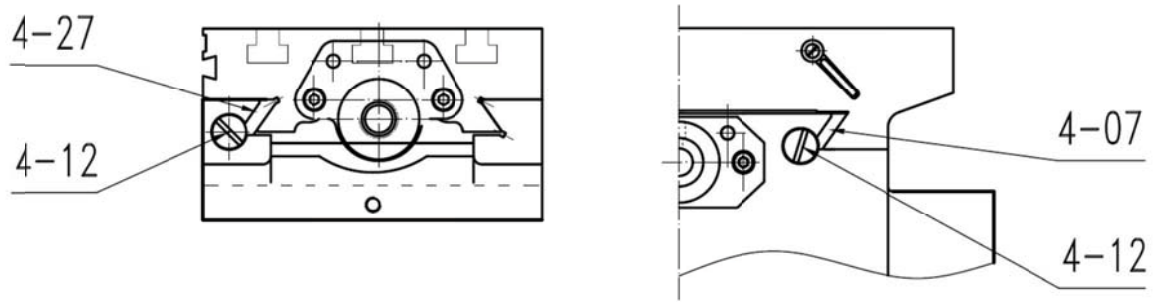

Fig.3

8. CLAMPING, TABLE BASE, AND MACHINE BASE

(1) When milling left and right, it is advisable to lock the fore and aft table travel to insure the accuracy of your work. To do this, tighten the leaf screw (4-13) located on the right side of the table base (Fig.4).

(2) To tighten the left and right travel of the table for fore and aft milling. Tighten the two small leaf screws (4-13) on the front of the table base (Fig.4).

(3) Adjustable travel stops are provided on the front of the table for control of cross travel and the desired milling length.

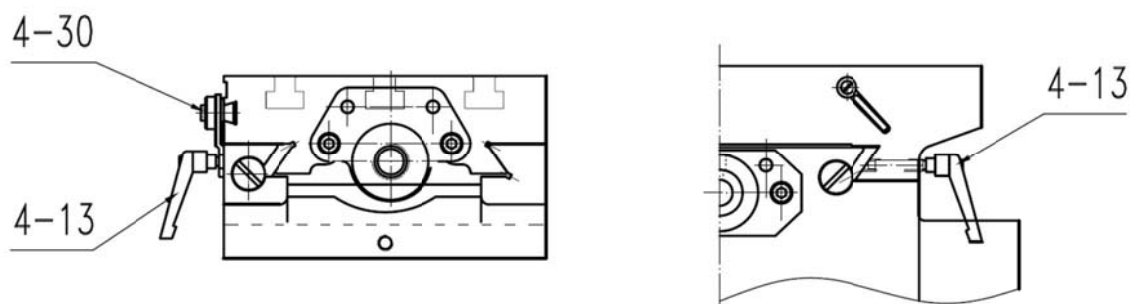
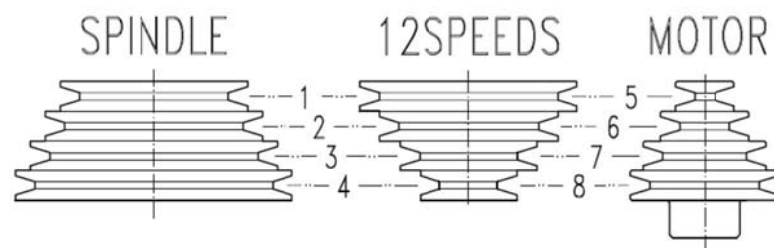

Fig.4

9.SPEED CHANGING

- (1)Turn power off .
- (2)Remove belt cover.
- (3)Loosen motor mount leaf screw.
- (4)Push motor in order to loosen belts(right side of motor mount is fixed left side with motor screw to tighten or loosen belts.
- (5)Loosen two screws of base for speed change pulley that also adjust, the location of base speed change pulley.
- (6)Select the suitable RPM from speed charts of Fig.5.6.
- (7)Tighten two screws of base for speed change pulley and the bolt of motor mount lock.
- (8)Cover the belt cover before turn power on.



50Hz	60Hz	BELT POSITION	50Hz	60Hz	BELT POSITION
100	140	4-5	640	819	1-6
160	219	3-5	865	1075	2-7
190	263	4-6	1010	1238	3-8
230	317	2-5	1205	1450	1-7
305	413	3-6	1500	1770	2-8
365	475	4-7	2080	2436	1-8

Fig.5

The way to open pulley cover.

When need to adjust belt and change speed. First to open belt top cover and open the buckle of belt cover, then open the pulley cover. After this step to close the pulley cover with counter clockwise step to fit it.

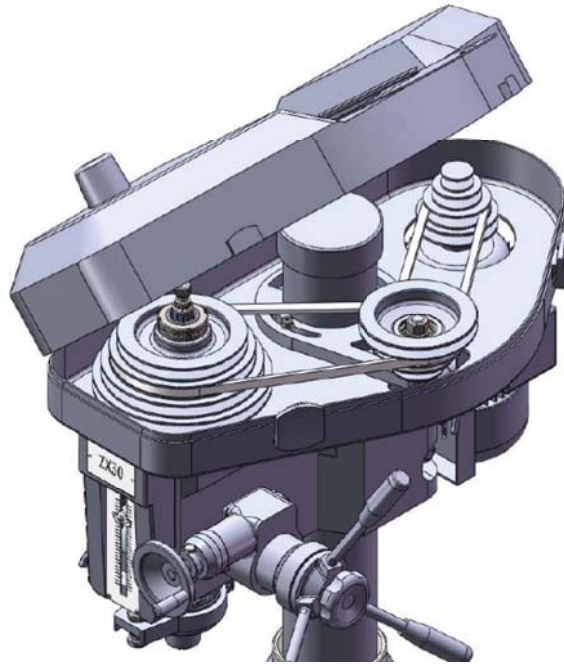

Fog.6

10.TO CHANGE TOOLS

(1)Removing Face Mill or Drill Chuck Arbor.

Loosen the draw bar bolt at the top of the spindle approximately 2 turns with a wrench, Rap the top of the spindle sharply with a mallet.

After taper has been broken loose hold chuck arbor in one hand and unscrew spindle with the other hand.

(2)To in stall Face Mill or Cutter Arbor

Insert cutter and cutter arbor into the taper of spindle. Tighten arbor bolt securely.but do not overtighten.

(3)Removing taper Drills

(a)Turn down the arbor bolt and insert the taper drill into the spindle shaft.

(b)Turn the rapid down handle rod down nutil the oblong in the rack gera sleeve appears, line up this hole with the hole in the spindle. Insert Key through holes and strike lightly with a mallet.This will force the taper drill out.

11.ORDERING REPLACEMENT PARTS

Complete parts list is attached. If parts are needed, contact your local distributor.

12.TAPPING EQUIPMENT REQUIREMENT

This machine can be equipped with an electric switch for tapping operation clockwise or counterclockwise, and the working depth also can be adjusted by the limit switch(Electric switch will be installed according to your requirement, and you must pay the cost only).

13.SPECIFICATION OF T-SLOT

This size of T-slot on table as Fig.7.

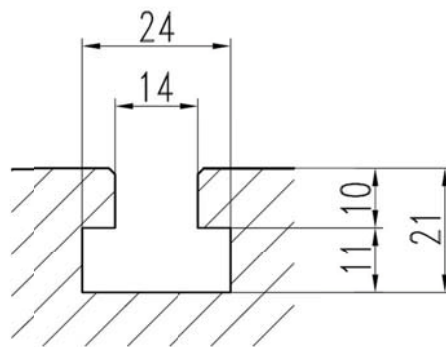

Fig.7

14.TROUBLE SHOOTING

(1)No running after switch on.

(a)Main switch interruption while volts irregular----Adjust input voltage and draw back the main switch .

(b)Break down of fuse in switch box----Replace with new one.

(c)In case of too much current, the overload relay jumps away automatically ----Press the overload relay and it will return to the correct position.

(2)Motor overheat and No power.

- (a)Overload----Decrease the load of feed.
 - (b)Lower voltage----Adjust to accurate Voltage.
 - (c)Spoiled contact point of magnetic switch----Replace with new one.
 - (d)Breakdown of overload relay----Connect it or replace with new one.
 - (e)Motor is poor----Replace with new one.
 - (f)Break down of fuse or poor contact with wire(it is easily spoil motor while short circuit)----Switch off power source at once and replace fuse with new one.
 - (g)The tension of pulley V-belt too tight----Adjust for proper tension of V-Belt.
 - (h)If this machine with the tapping attachment, there is an aid plum screw fix on the motor mount in order to avoid the motor pulleys shake while turning.
- (3)The temperature of spindle bearing is too hot
- (a)Grease is insufficient----Fill the grease.
 - (b)The spindle bearing is too tight----Turning with no speed and feel the tightness with hand.
 - (c) Turning with high speed for a long time----Turn it to lightly cutting.
- (4)Lack of power with main spindle revolving
- (a)The tension of V-belt too loose----Adjust for proper tension of V-belt.
 - (b)Motor has burned out----Change a new motor.
 - (c)Fuse has burned out----Replace with new one.
- (5)Spindle turn has not balanced
- (a)The gap of spindle bearing too wide----Adjust bolt in proper.
 - (b)Loosening of leaf bolt----Turn and fasten in place.
 - (c)Feed too deep----Decrease depth of feed.
- (6)Shake of spindle and roughness of working surface has taken place during performance.
- (a)the gap of spindle bearing too wide----Adjust the gap in proper or re place bearing with new one.
 - (b)Spindle loosening up and down----Make two of inner bearing covers on the top tight each other. Do not overtighten two inner bearing covers with the taper

bearing; it is ok as long as no gap between them.

(c)The gap of taper sliding plate too wide----Adjust the tension of bolt in proper.

(d)Loosening of chuck----Fasten chuck.

(e)Cutter is dull----Resharpen it.

(f)Workpiece has not hold firmly----Be sure to tighten workpiece.

(7)Micro feed does not work smoothly

(a)Loosening of clutch----Be sure to tighten it.

(b)Worm and worm shaft has worn out----Replace with new one.

(c)Loosenig of handwheel fixed screw----Be sure to tighten it.

(8)Without accuracy in performance

(a)Imbalance of heavy workpiece----Must be considerate of the principle of balance while holding workpiece.

(b)Often use of hammer to strike workpiece----Forbidden to use hammer to strike workpiece.

(c)Inaccurate horizontal table----Check and maintain table for keeping accurate horizontal after a period of use.

15.MAINTAINING

That' s easier to keep machine in good condition or best performance by means of maintaining, it at any time than remedy it after it is out of order.

(1)Daily maintenance (by operator).

(a)Fill the lubricant before starring machining machine everyday.

(b)If the temperature of spindle caused overheating or strange noise, stop machine immediately to check it for keeping accurate performance.

(c)Keep work area clean; release vise, cutter. Workpiece from table; switch off power source; take chip or dust away from machine and follow instructions lubricating or coating rust-proof oil before leaving.

(2)Weekly maintenance

(a) Clean and coat the cross leading screw with oil.

(b) Check to see if sliding surface and turning parts of lack lubricant. If the lubricant is insufficient, fill it.

(3) Monthly maintenance

(a) Adjust the accurate gap of slide both in right and left and forward and backward feed.

(b) Lubricate bearing, worm shaft to avoid wear.

(4) Yearly maintenance

(a) Adjust table to horizontal position for maintenance of accuracy.

(b) Check electric cord, plugs, switches at least once a year to avoid loosening or wearing.

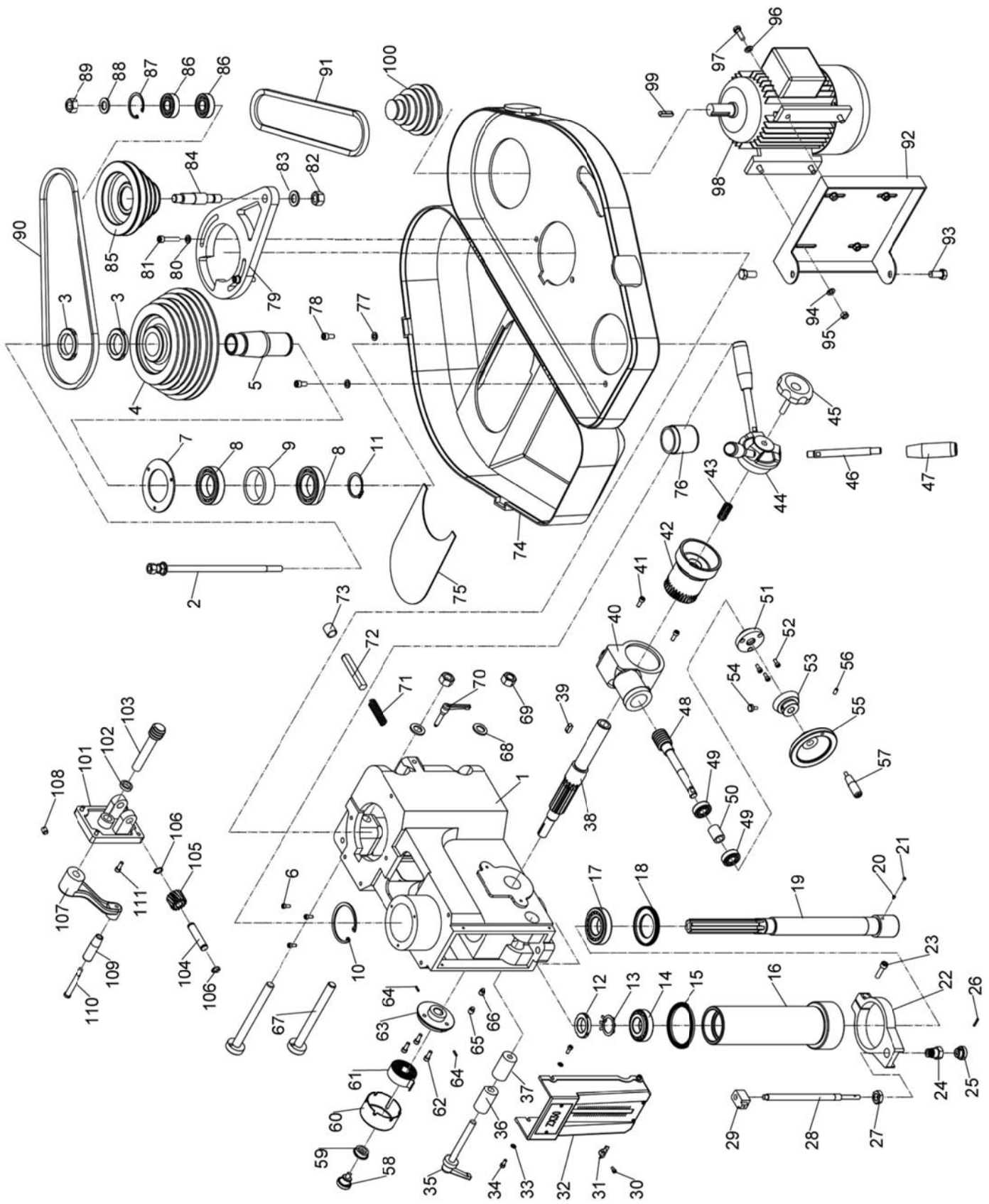

Spindle head parts list

NO	QTY	CODE	NAME	NO	QTY	CODE	NAME
1	1	0501	HEAD CASTING	41	2		CAP SCREW M6X20
2	1	0518	DRAW BAR	42	1	0504	WORM GEAR
3	2		SPINDLE LOCK NUT M42x1.5	43	1	0525.9	COMPRESSION SPRING
4	1	0513	SPINDLE PULLEY	44	1	0525.8	LEVER BASE
5	1	0530	SPINDLE TAPER SLEEVE	45	1	0569	KNOB BOLT M10-1.5x45
6	3		CAP SCREW M5x12	46	3	0549.1	LEVER M12-1.75X145
7	1	0519	OUT BEARING PLATE	47	3	0549.2	TAPERED KNOB M12-1.75
8	2		BALL BEARING 6009ZZ	48	1	0509	WORM SHAFT
9	1	0553	SPACER 74MM	49	2		BALL BEARING 6202ZZ
10	1		INT RETAINING RING 75MM	50	1	0524	SPACER 29MM
11	1		EXT RETAINING RING 45MM	51	1	0508	WORM SHAFT COVER
12	1		LOCK NUT M30x1.5	52	2		CAP SCREW M5x16
13	1		LOCK WASHER 30	53	1	0505	FINE DOWNFEED GRADUATED DIAL
14	1		TAPERED ROLLER BEARING 30206	54	1	0107	KNURLED THUMB SCREW M5X12
15	1	0528	RUBBER FLANGE	55	1	0525.1	FINE DOWNFEED HANDWHEEL
16	1	0537	SPINDLE SLEEVE	56	1		SCREW M6X12
17	1		TAPERED ROLLER BEARING 30207	57	1	0525.2	HANDWHEEL HANDLE
18	1	0538	SPINDLE CUP	58	1	0566	KNOB BOLT M8-1.25x12
19	1	0536	SPINDLE R-8	59	1	0563	LOCK WASHER 8
20	1		SET SCREW M5x6 DOG-PT	60	1	05061	TORSION SPRING COVER
21	1		SET SCREW M5x6	61	1	05062	COILED SPRING
22	1	0522	QUILL CLAMP	62	3		CAP SCREW M6X12
23	1		CAP SCREW M8X30	63	1	0507	SPRING BASE
24	1	0522.4	INT THREADED SHOULDER BOLT	64	2		ROLL PIN 3X12
25	1	0522.3	Depth rod knurled thumb knob	65	1		CAP SCREW M10x12
26	1		PIN 3X18	66	1		SET SCREW M10x12
27	1		HEX NUT M16-2 THIN	67	2	05017	HEX BOLT M16X178
28	1	0522.5	STUD-FT M12-1.75X230	68	2		FLAT WASHER 16
29	1	0522.6	DEPTH ROD DOG	69	2		HEX NUT M16
30	1		CAP SCREW M4-07X8	70	1	450305	LOCK HANDLE M8-1.25x25
31	1	0550	DEPTH POINTER	71	1	0552	COMPRESSION SPRING
32	1	0548	FRONT COVER PLATE ASSEMBLY	72	1	0567	BELT TENSION PIN
33	2		WASHER 5	73	1	0568	RUBBER PAD
34	2		SCREW M5X12	74	1	0554	BELT COVER
35	1	0534	LOCK LEVER SHAFT	75	1	0554.2	PROTECTIVE PLATE
36	1	0542	OUTER LOCK PLUNGER	76	1	0554.3	SPINDLE COVER
37	1	0543	INNER LOCK PLUNGER	77	2		FLAT WASHER 8
38	1	0525	PINION SHAFT	78	2		HEX BOLT M8X20
39	1		KEY 8x8x20	79	1	0512	PULLEY IDLER PLATE
40	1	0502	WORM GEAR HOUSING	80	2		FLAT WASHER 8

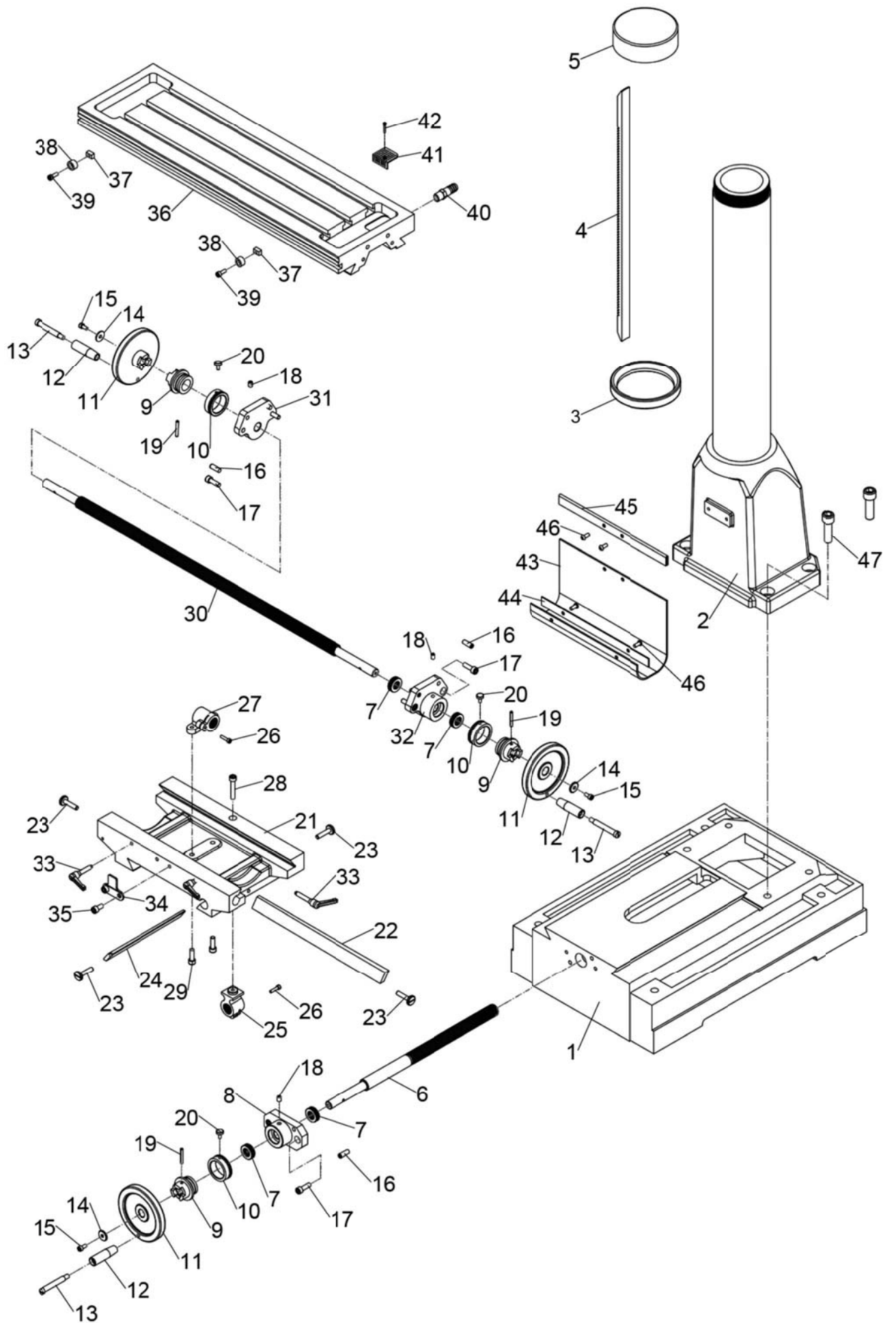

Base parts list

No	Qty	Code	Name	No	Qty	Code	Name
1	1	300102	Base	41	1	300401.1	Coolant drain screen
2	1	300201	Column base	42	2		Screw M3×25
3	1	300204	Column ring	43	1	300206	Way cover
4	1	300203	Elevation rack	44	2	300307	Way cover uppfr plate
5	1	300202	Column cap	45	1	300205	Way cover uppfr plate
6	1	300102	Y-Axis leadscrew	46	4		Cap screw M6×16
7	4		Thrust bearing 51103	47	4		Cap screw M16×60
8	1	300104	Left flange				
9	3	300105	Dial clutch				
10	3	300106	Table graduated dial				
11	3	10301	Table handwheel				
12	3	300110	Handwheel handle				
13	3	300109	Shoulder screw				
14	3	300112	Flat washer 6mm				
15	3		Cap screw M6×16				
16	6		Roll pin 8×30				
17	6		Cap screw M8×25				
18	3		Ball oiler 8mm				
19	3		Roll pin 5×35				
20	3	300107	Knurled thumb screw				
21	1	300301	Saddle				
22	1	300306	X-Axis gib				
23	4	300305	Gib adjustment screw				
24	1	300304	Y-Axis gib				
25	4	300103	Y-Axis leadscrew nut				
26	2		Cap screw M5×20				
27	1	300302	X-Axis leadscrew nut				
28	1		Cap screw M8×45				
29	2		Cap screw M8×25				
30	1	300402	X-Axis leadscrew				
31	1	300404	X-Axis leadscrew bracked(LH)				
32	1	300407	X-Axis leadscrew bracked(RH)				
33	3		Adjustment handle				
34	1	300410	Limit stop block				
35	2		Cap screw M8×16				
36	1	300401	Table				
37	2	300408	Hex nut M6				
38	2	300409	Limit stop				
39	2		Cap screw M6×16				
40	1	300411	Hose connector				



Certificate of Inspection
for
Geared Head Milling and Drilling Machine
Model ZX30

Dispatch No.:

The machine has been qualified and may be permitted to dispatch

Head of Inspection Depart _____ Date _____

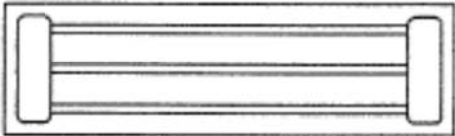
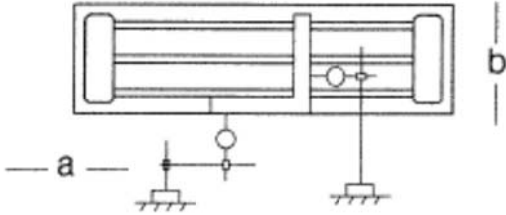
Director _____ Date _____

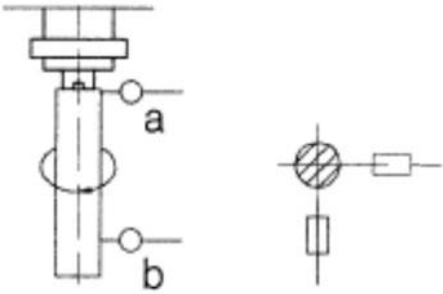
<p style="text-align: center;">ACCURACY TEST FOR MILLING & DRILLING MACHINE</p>		<p style="text-align: center;">Total 2</p>	
		<p style="text-align: center;">P1</p>	
No.	Checking items	Tolerance	Error tested
G1	<p>The flatness of worktable surface</p> 	<p>0.025 for any tesred length 200 Max 0.08</p>	
G2	<p>Squareness of worktable longitudinal movement to cross movement</p> 	<p>0.04/300</p>	
G3	<p>Parallelism of worktable longitudinal movement to the base T-slot</p> 	<p>0.05</p>	
G4	<p>Ran-out of spindle hole center line</p> 	<p>a)Near spindle nose 0.015 b)At a distance of 100 form spindle nose 0.02</p>	

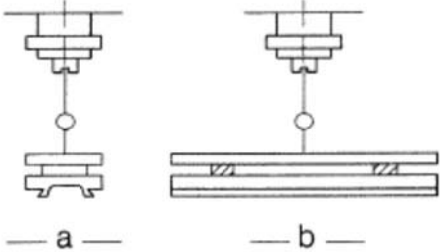
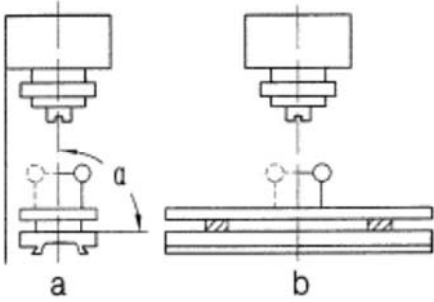
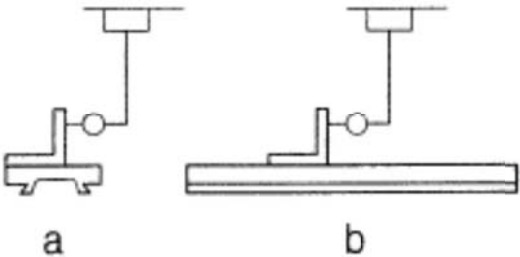
<p style="text-align: center;">ACCURACY TEST FOR MILLING & DRILLING MACHINE</p>		<p style="text-align: center;">Total 2</p>	
		<p style="text-align: center;">P1</p>	
No.	Checking items	Tolerance	Error tested
<p>G5</p>	<p>Parallelism of worktable movement to worktable surface</p>  <p style="text-align: center;">— a — — b —</p>	<p>a 0.02 for any 100 testing length</p> <p>b 0.03 for any 300 testing Max 0.06</p>	
<p>G6</p>	<p>Squareness of spindle rotating line to worktable surface</p>  <p style="text-align: center;">a b</p>	<p>a 0.05/300</p> <p>a ≤ 90°</p> <p>b 0.05/300</p>	
<p>G7</p>	<p>Squareness of spindle sleeve vertical movement to worktable surface</p>  <p style="text-align: center;">a b</p>	<p>a 0.05/100</p> <p>b 0.05/100</p>	

PACKING LIST FOR
GEARED HEAD DRILLING & MILLING MACHINE ZX30

Series No :		Dimension :			
G/W :		N/W :			
No.	Name	Spec	Model	Quantity	Remark
1	Milling & drilling machine		ZX30	1	
2	Draw bar	M12		1	
3	Adapter	MT3/MT2		1	
4	Taper shank for drilling chuck	MT3/B16		1	
5	Drilling chuck	Φ 1 ~ Φ 13		1	
6	T slot bolt	M12×55		2	
7	Washer	12		2	
8	Nut	M12		2	
9	Tilted wedge			1	
10	Spanner	19-24		1	
11	Hex wrench set	3、4、5、		1	
12	Oil gun			1	
13	Instruction Manual			1	
14	Certificate of inspection			1	
15	Packing list			1	

Packing inspector_____

Date_____